

Specification for the Driver Coil Modules  
Capacitor Charge/Discharge Power Supply (CCDPS) for FLARE

March 10, 2016

## Contents

<b>1</b>	<b>Specifications for Driver Coil (DC-I and -O) bank modules</b>	<b>4</b>
1.1	Description . . . . .	4
1.2	Full Assembly . . . . .	7
1.2.1	DC-I module . . . . .	7
1.2.2	Full Assembly: DC-O module . . . . .	8
1.3	Capacitors . . . . .	9
1.4	Forward Switch . . . . .	9
1.5	Crowbar Diodes . . . . .	10
1.6	Buswork . . . . .	10
1.7	Charging . . . . .	10
1.8	Dump . . . . .	11
1.9	Harnessing . . . . .	12
1.10	Polarity switching . . . . .	12
1.11	Diagnostics . . . . .	12
1.12	Safety . . . . .	12
1.13	Cooling requirements . . . . .	12
1.14	Connection schematic . . . . .	12
1.15	Environmental requirements . . . . .	13
<b>2</b>	<b>References</b>	<b>14</b>
<b>3</b>	<b>Appendices</b>	<b>14</b>
3.1	Machining drawings and vendor specifications . . . . .	14

## List of Tables

1	Target parameters for DC bank . . . . .	4
---	---	---

## List of Figures

1	Driver Coil Circuit Schematic . . . . .	4
2	PSpice DCI Schematic and Analysis . . . . .	5
3	PSpice DCO Schematic and Analysis . . . . .	6
4	Engineering design point for bank module . . . . .	7
5	Engineering design point for bank module . . . . .	8
6	Detail of the cap headers for the DCI (left) and DCO (right) bank modules. . . . .	9
7	Detail of the switch for the DCI and DCO banks (they are identical). . . . .	10
8	Charge dump relay . . . . .	10
9	Dump detail for the DC bank module. . . . .	11
10	Connections . . . . .	13
11	Schematic for charge, dump and ground relay control. . . . .	14
12	DCI Capacitor Header Adapter for Nipple . . . . .	15
13	DCO Capacitor Header Adapter for Nipple . . . . .	16
14	Aluminum Nipple . . . . .	17
15	Diode Clamp Upper/Lower . . . . .	18
16	Nipple Cap . . . . .	19

# 1 Specifications for Driver Coil (DC-I and -O) bank modules

## 1.1 Description

Bank schematic is shown in Fig. 1 for each of the two DC bank modules. Starting on the left side of the figure, the module is charged by connecting both positive and negative supply lines. A power supply protection circuit is shown (please refer to the Charge Specification for details). A bleed resistor is connected in parallel with the capacitor and is used to slowly drain bank charge in case of failure of all other dumps (i.e. if left alone overnight the bank will passively discharge below the NFPA 70E safe approach threshold of 50 V). Before each shot, the dump load relays are opened. Then the charging relays are closed and the charging supply charges the caps. When the set-point is reached, the charging switches are opened. The capacitors are then discharged through the inductive and resistive load of the coil, and crowbarred with a delay corresponding to peak current. For DC-I and DC-O, the first swing current will always be greater than zero, and a switch is used to crowbar the circuit. Following a shot, the dump switch is closed to ensure the capacitors are fully discharged. Each of the components will be described in the following sections.

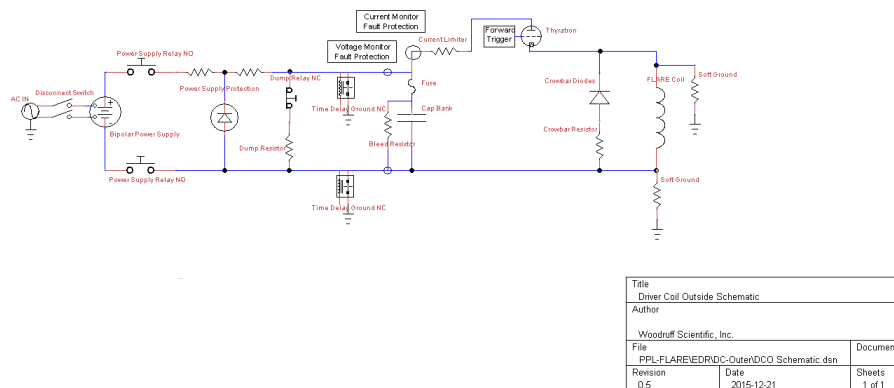

Figure 1: Driver Coil Circuit Schematic

The DC bank modules are designed to energize the inboard and outboard Driver Coil set, providing a current pulse per Fig. 2 and Fig. 3, meeting the specifications in Table 1. The power supply system shall be designed for a minimum of 10 years design life and a minimum of 100,000 full power shots with regular maintenance.

	DC-I	DC-O
# Sub-Coils	2	2
V (Volts)	60000	60000
I <sub>max</sub> (A)	50000	50000
Day 1	0	0
Peak I (kA)	50	50
trise (ms)	< 0.01	< 0.03
tcrowbar	Peak	Peak
Swing I <sub>min</sub>	+ve	+ve

Table 1: Target parameters for DC bank

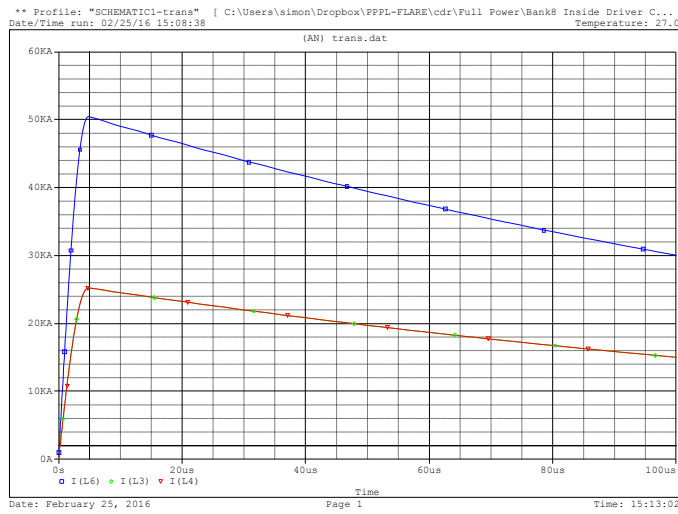
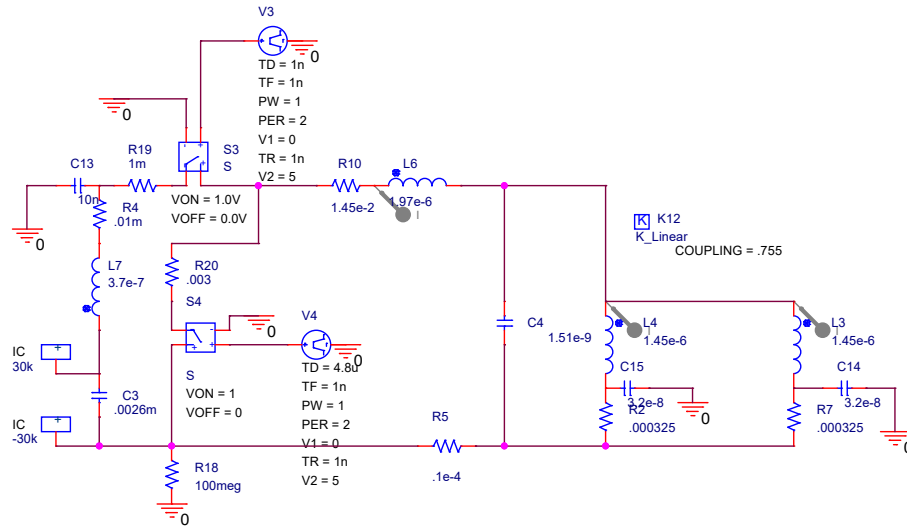

Figure 2: PSpice DCI Schematic and Analysis

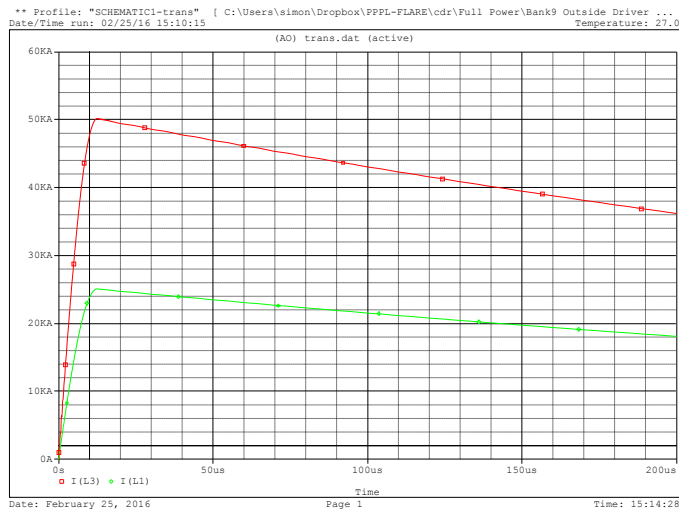
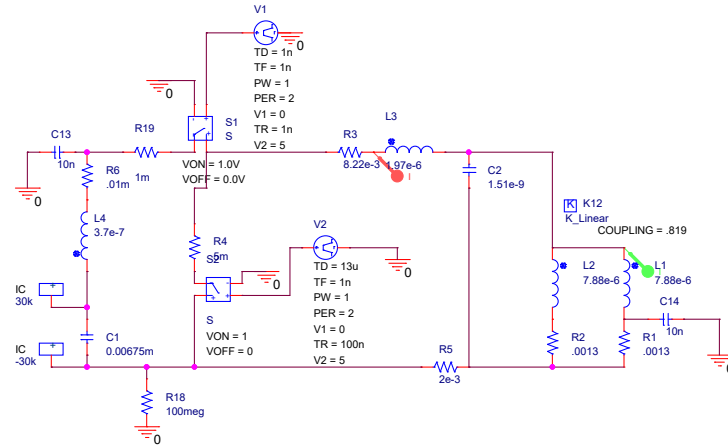

Figure 3: PSpice DCO Schematic and Analysis

## 1.2 Full Assembly

### 1.2.1 DC-I module

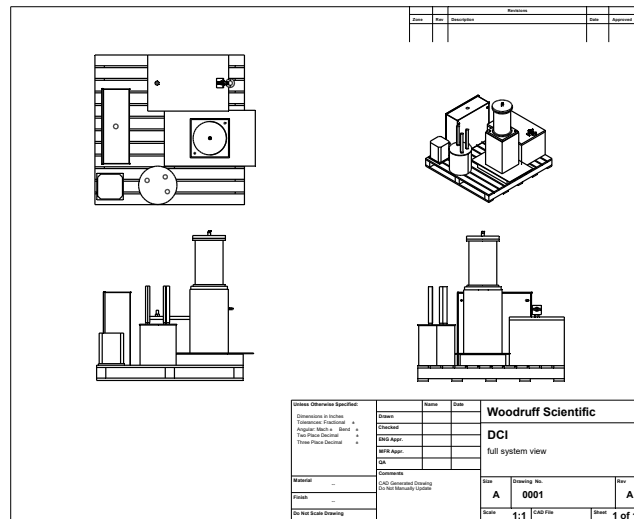
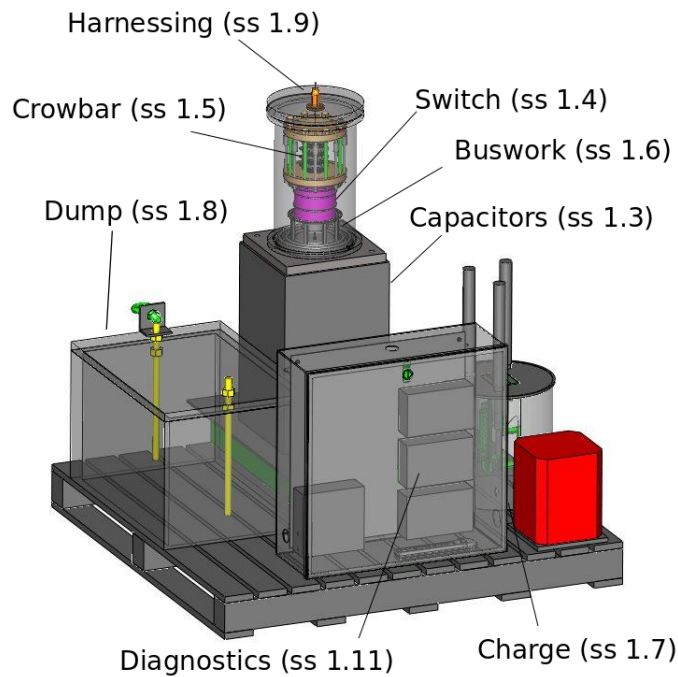

Figure 4: Engineering design point for bank module

Fig. 4 shows the full bank assembly mounted on one 36 inch square steel pallet. The full assembly will have a footprint smaller than 16sqft with a maximum of 64sqft for egress and maintenance (2 feet on each side), and will be engineered as 1 module that can be transported and installed onsite with only a small number of connections (connections for 110V power, high voltage and trigger lines (see more details below and connection table below)). The DC Bank and all related components will be mounted on 2 36"x36" standard pallets, total height under 50 inches, total weight per pallet of 1200lbs. Assembly instructions will be provided separately.

1.2.2 Full Assembly: DC-O module

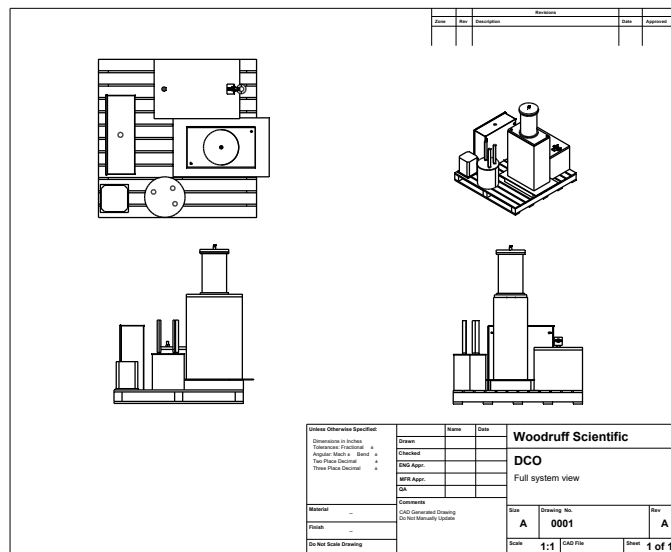
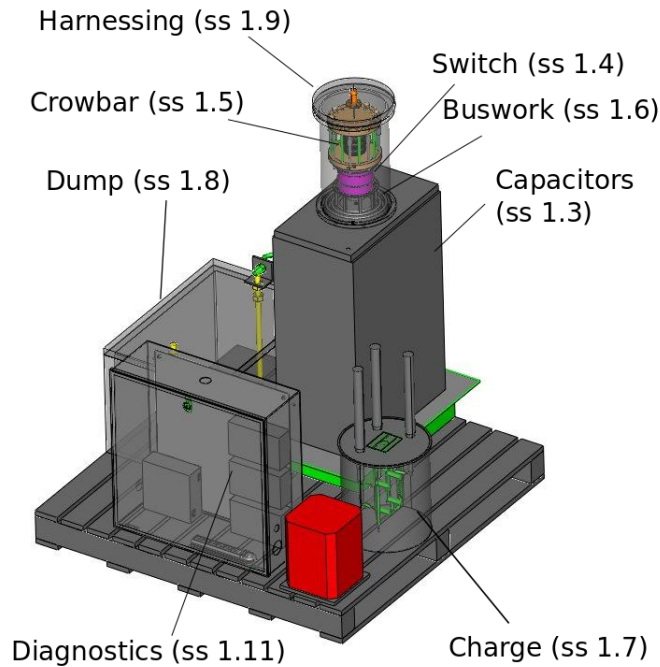

Figure 5: Engineering design point for bank module

Fig. 5 shows the full bank assembly mounted on one 36 inch square steel pallet. The full assembly will have a footprint smaller than 16sqft with a maximum of 64sqft for egress and maintenance (2 feet on each side), and will be engineered as 1 module that can be transported and installed on-site with only a small number of connections (connections for 110V power, height voltage and trigger lines (see more details below and connection table below)). The full DC Bank (DC-I and DC-O) and all related components will be mounted on 2 36"x36" standard pallets, total height under 50 inches, total weight per pallet of 1200lbs. Assembly instructions will be provided separately.



### 1.3 Capacitors

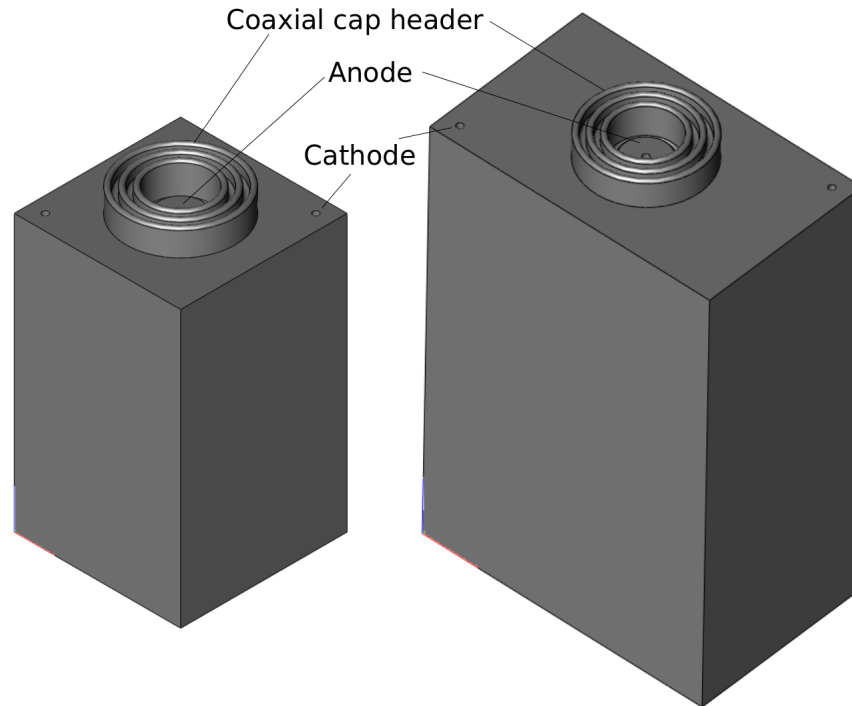

Figure 6: Detail of the cap headers for the DCI (left) and DCO (right) bank modules.

The DC Bank will use 2 60kV Capacitors, with 2.5uF on the DC-I and 7.5uF on the DC-O, by Richardson Electronics. The capacitors are expected to see reversal voltages during the experimental shots. Capacitor casing will be hot, and in bipolar charging operation, will see -30kV. Cap casing is therefore isolated from the pallet (at ground) by multiple layers of mylar, and a 3" thick high density extruded polystyrene sheet (to ensure stand-off and even-distribution of weight on the mylar). The caps are rated for 80% discharge voltage reversal. The capacitors are expected to survive at least 500,000 full power shots without failure, per cap manufacturer specification see appendix for the Richardson specification. Each capacitor unit is self-protected with a resistive load between cap and switch consisting of 8 stainless resistive shunts connecting the anode of the capacitor to the anode of the switch. Fuses are omitted for this bank. Energy dumping resistor(s) shall be specified for safe dissipation of stored energy (see Charge section below). The dissipation time should be limited to the shorter of the relevant industrial standards or the experimental needs.

### 1.4 Forward Switch

Operation at high voltages and with short current pulses allows for selection of a thyatron switch (see e.g. TDI4-100k/75H THYRATRON, specifications in the Appendix). The thyratrons are expected to see reverse voltage and pulse currents. Life time of the thyatron contact shall not be significantly shortened or the minimum design life of the equipment should be maintained. The thyratrons are expected to survive a minimum of 10,000 full power shots without failure. Thyratrons require heating and optical trigger units, both of which are provided in the BOM. In contrast to all other banks, the switch and diodes are mounted as a single unit, as shown in Fig. 7 - the thyatron is mounted on the anode and return connections are made to the outer conductor.

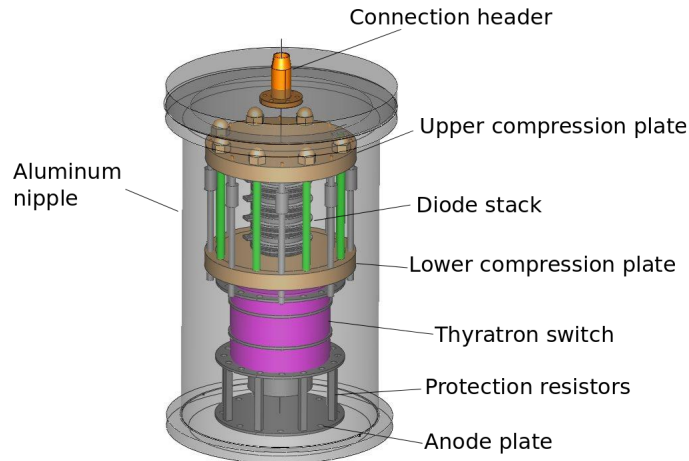

Figure 7: Detail of the switch for the DCI and DCO banks (they are identical).

### 1.5 Crowbar Diodes

Five high voltage (VRE) diodes rated to 15KV will be used in a series stack to crowbar the circuit. This can be accomplished due to the short duration and relatively low current in the DC-I/O circuits.

### 1.6 Buswork

The buswork for the DC banks consist of a copper cable header mounted on top of the capacitor, forward switch, and crowbar assembly. Stainless steel posts connecting to the capacitor to the thyatron offer fault protection current limiting resistance.

### 1.7 Charging

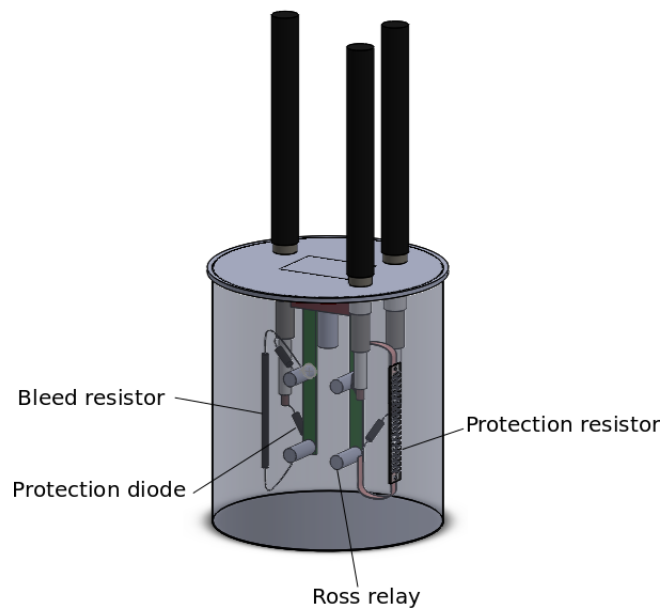

Figure 8: Charge dump relay

The charging supply will consist of two Ultravolt supplies (30C24-P|N125 for DC-O and 30C24-P|N60 for DC-I). The two output lines each include a series resistor to improve regulation and limit output current under fault conditions. The lines are then split to run a cable to each capacitor module. At the capacitor module, the charge cable is connected across a diode that protects the charge supply in the event of a bank pre-fire (when the charge supply is connected to the bank). The diode prevents any bank reversal during pre-fire from imposing a reverse voltage at the charge supply. After the diode is a resistor that limits the charge current for the bank (and limits the protection diode current under reversal). The final connection to the capacitor busswork is made via a normally-open DPST Ross relay which is only connected for charging, and is disconnected immediately prior to programmed discharge. Please refer to the separate specification for the charging supplies (treated as a separate sub-assembly). In parallel with each capacitor is a bleed resistor. These are a redundant dump mechanism for the stored energy. These resistors are sized to discharge the bank to below 50 volts over 12 hours. The bleed resistors are a passive “last resort” safing mechanism in case of failure of the water dump or loss of buswork connections, allowing the operator to leave the bank overnight to dissipate its stored energy. The bleed resistor shown in Fig. 8 is a 90kV 20W Ohmite MOX970 (see spec in appendix), using 2G $\Omega$  on the DC-I module and 800M $\Omega$  on the DC-O module. Charging cable is terminated at the relay with a custom connector, see Fig. 8.

## 1.8 Dump

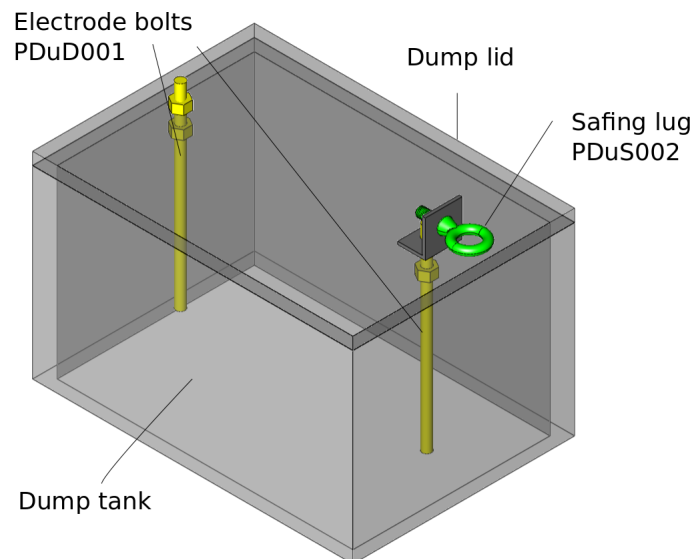

Figure 9: Dump detail for the DC bank module.

Each capacitor module includes a resistor sized to dissipate the full-charge energy of the bank. The resistor material is an aqueous solution of copper sulfate with brass electrodes in a polycarbonate reservoir. The electrolyte concentration is tuned to discharge the bank to below 50 volts (the NFPA 70E safety threshold) within 30 seconds. This dump rate was chosen based upon a conservative estimate of the time required from removal of the Kirk key at the operator station to entry of the bank enclosure. The dump sizing is also designed to allow several sequential full-energy dumps at 3 minute intervals, but in this operation mode the resistor temperature shall be monitored remotely by the operator to ensure the temperature does not exceed 60°C (as per ASTM C1055) and that the water level is maintained. The normally-closed dump relay on each module (Ross E40-NC) will be energized only during charge, and will be de-energized to engage the dump upon removal of the Kirk key or at any emergency stop or interlock break. A temperature sensor is located on the outside lower section of each dump.

## 1.9 Harnessing

The harnessing sub-assembly comprises all of the interconnecting power cables from the CCDPS to the FLARE machine. The cabling will be triax of suitable current rating (see e.g. Dielectric Sciences specification in the Appendix). On DC-I, 2 cables will connect to the cable header located close to the switches and between the dumps. On DC-O, 3 cables will be used. Cable trays will be used to route cables from the capacitor banks to the device.

## 1.10 Polarity switching

No polarity switch is required for this module.

## 1.11 Diagnostics

Diagnostics must be provided to measure the forward current in the bus leading to the forward switch (in this bank it is placed beneath the nipple cap), the voltage of the bank module using a voltage divider, and the temperature of the over-current protection resistor, the temperature in the dump resistor and the temperature at the anode of the ignitrons. Each of these diagnostic measurements must be transmitted along a fiber-optic connection to the DAQ. Please see separate DAQ specifications for further information.

## 1.12 Safety

Monitoring (analog and digital voltage monitoring) will be required. A voltage divider at the bank will be used to monitor the charging voltage on the control computer (see specification for DAQ), and provide a signal for a panel-mounted analog indicator at the entry to the enclosure. The DC bank modules will be housed in a bay that separated it from other bank modules. Each side of the bank module may be separated by a 1/4 inch steel blast shield. The enclosure will be interlocked and procedures will be present to disable the bank before personnel access.

## 1.13 Cooling requirements

Water cooling is not required for the DC bank modules.

## 1.14 Connection schematic

The connection schematic shows all of the connections that need to be made to the bank modules, power and control systems. From the left of Fig. 10, 208 and 110 power is fed to the bank enclosures via a Kirk key controlled isolation switch. This same switch can be energized by an Emergency Stop (E-stop) button located in the control room (this E-stop is digitized by both the FLARE control DAQ and the CCDPS control DAQ). If energized, the switch will drop all power to the enclosure, thereby killing power to the HV dump (normally closed) and charge (normally open) relays, and dumping bank energy into the cap dumps. The 110 and 208 power is delivered to the charging supply rack (located on it's own separate pallet), and 110 is also delivered to an isolation transformer mounted on the bank module pallet. Connections to the load are made by multiple triax cables (described above). Water is connected to the ignitron switches along 1/4" tubes from a shared chiller unit. The charge, dump ground relays are controlled by individual fiber-optic-enabled switches, with pulse signals sent from the CCDPS DAQ rack (Schematic shown in Fig. 11). Temperature sensor data are transmitted by fiber-optics from the pallet to the DAQ after conversion of voltage to frequency, then reconvertng at the DAQ. A BNC connection is made from the current sensor integrator to the DAQ fast data acquisition (sampling at at least 1MHz). Timing synchronization is provided by the FLARE control DAQ. Switch firing is controlled here by the FLARE control computer and DAQ, by transmission of fire signal by fiber-optic connection. CCDPS DAQ requires 110V as input. CCDPS control computer requires 110V as input.

- Electrical input requirements: 208V three phase, 110V, less than 50 Amps (total for all banks at full charge is 100A)

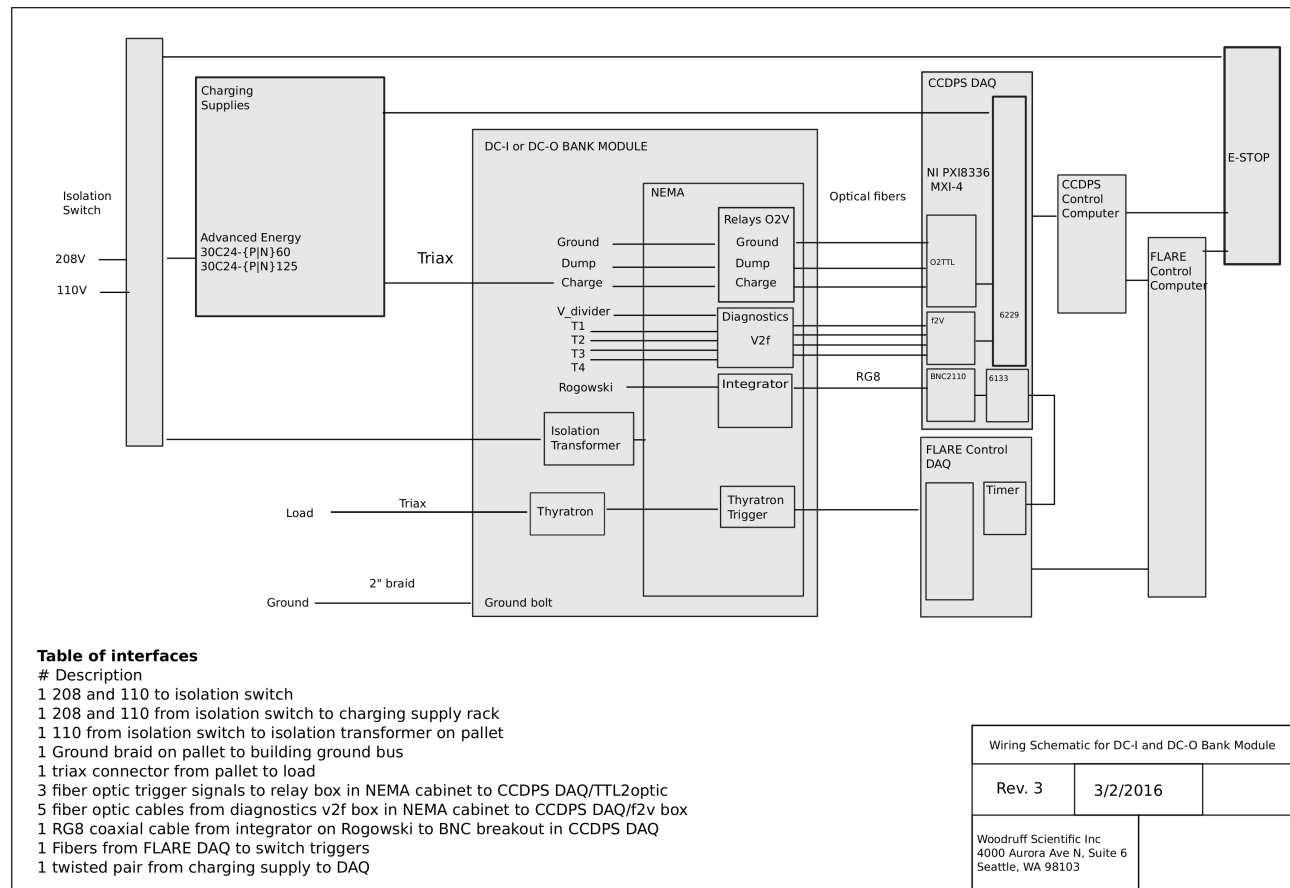
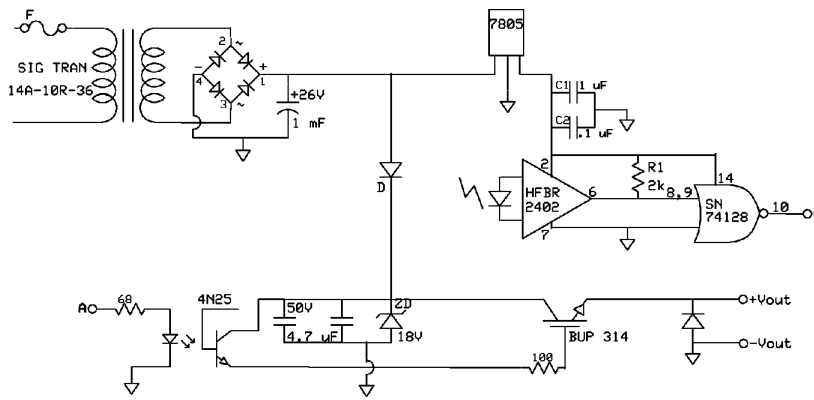

Figure 10: Connections

- Load requirements: as specified in [1]
- Cooling requirements: none.
- Environmental requirements: dust free, see below
- Control signals needed as inputs: ESTOP and triggers (see Fig. 10)
- Control signals as outputs: none.

### 1.15 Environmental requirements

The entire CCDPS is specified to operate at room temperature, and will tolerate seasonal variations in humidity without the need for any special AC, other than heater connections to the thyratrons. Ideally the banks will be placed in a dust-controlled environment (fans with filters, preferably with drywall to the ceiling), with minimal traffic to the enclosure.



<b>Woodruff Scientific</b>	
<b>Charge Relay Gate</b>	
Rev 1.0	
12/17/2009	

Figure 11: Schematic for charge, dump and ground relay control.

## 2 References

### References

- [1] Statement of Work for Design of Capacitor Charge/Discharge Power Supply (CCDPS) for FLARE FLARE-CCDPS-150828, Revision 0, Sept. 9th 2015

## 3 Appendices

### 3.1 Machining drawings and vendor specifications

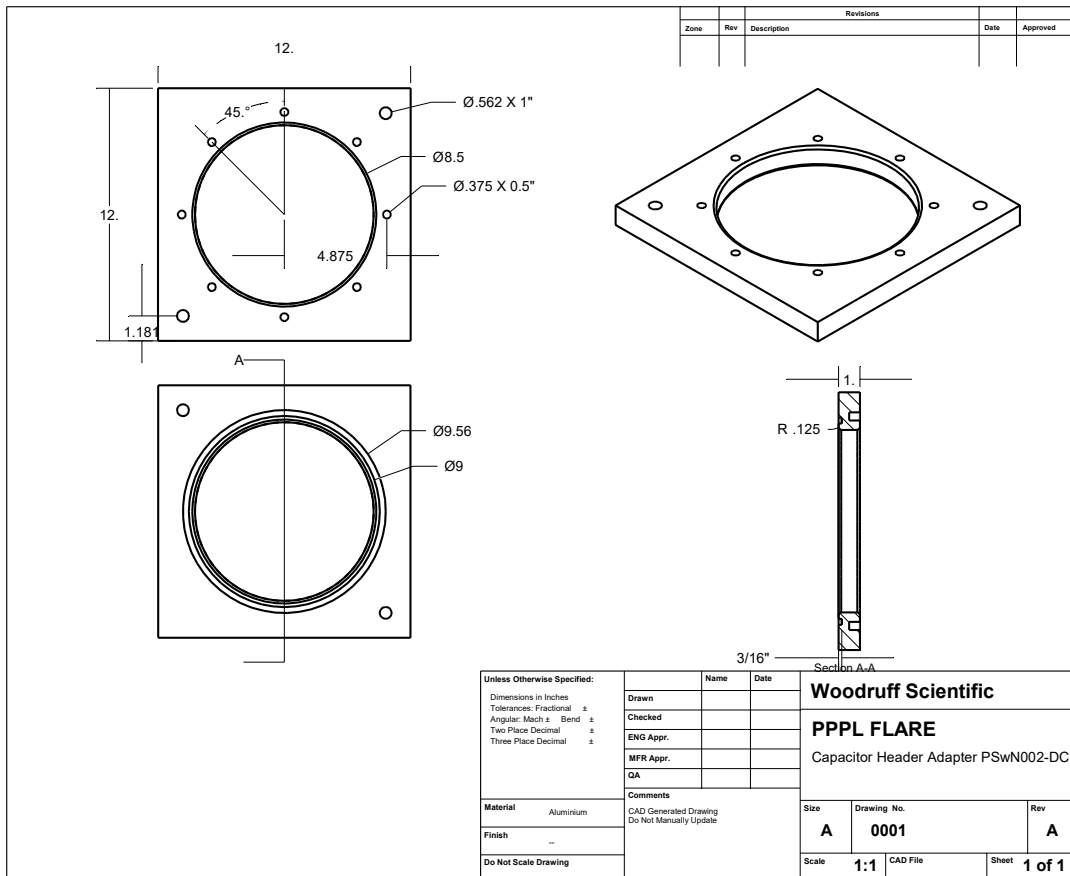

Figure 12: DCI Capacitor Header Adapter for Nipple

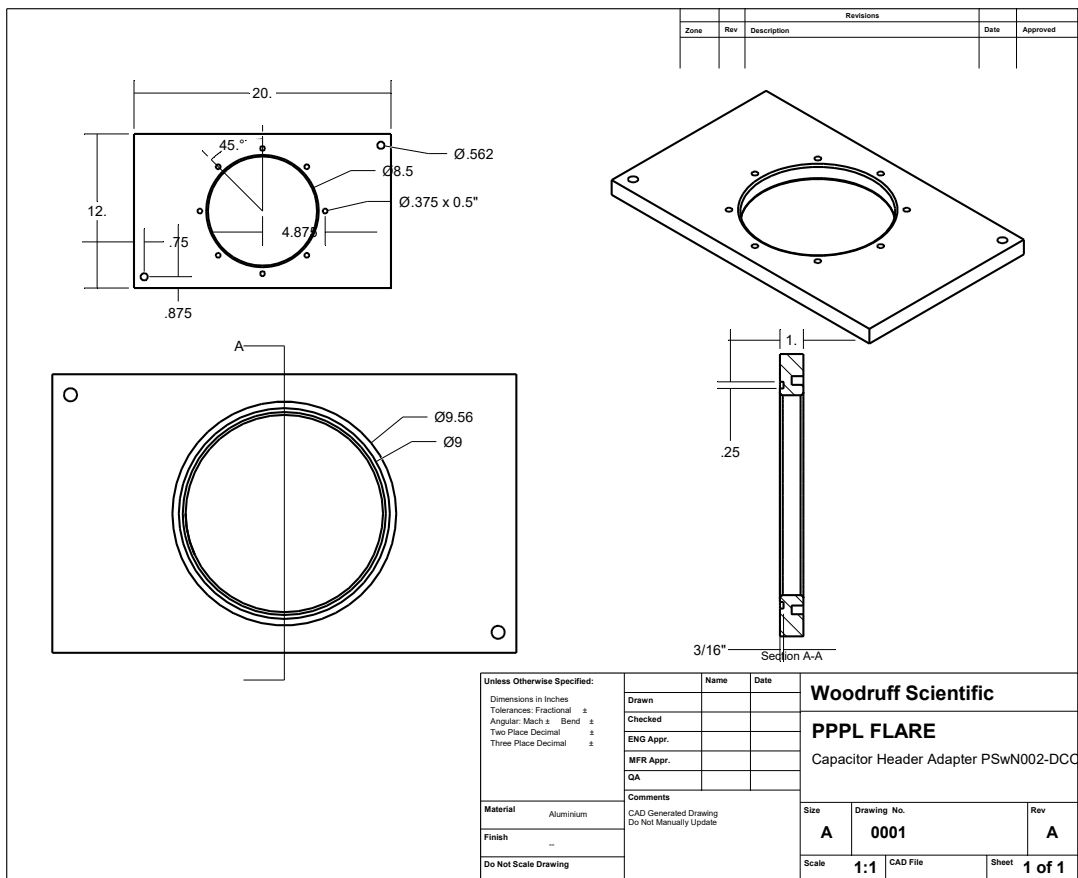

Figure 13: DCO Capacitor Header Adapter for Nipple



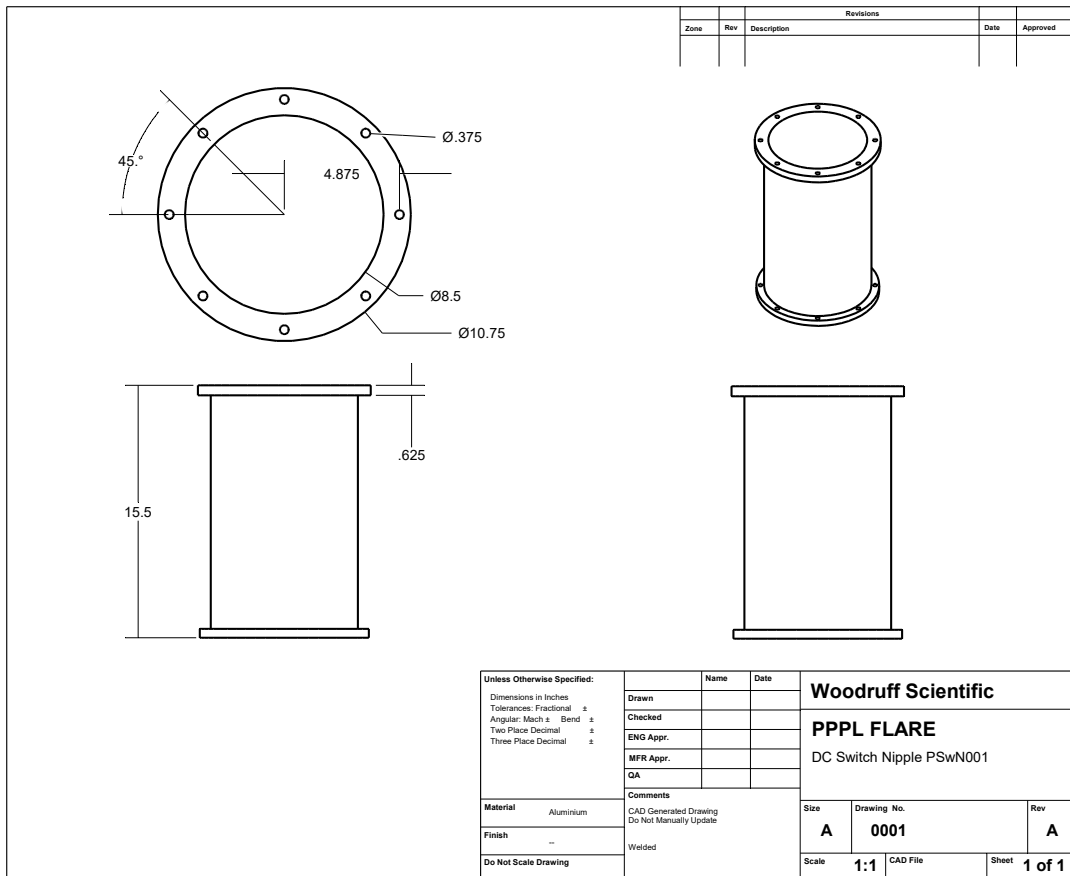

Figure 14: Aluminum Nipple

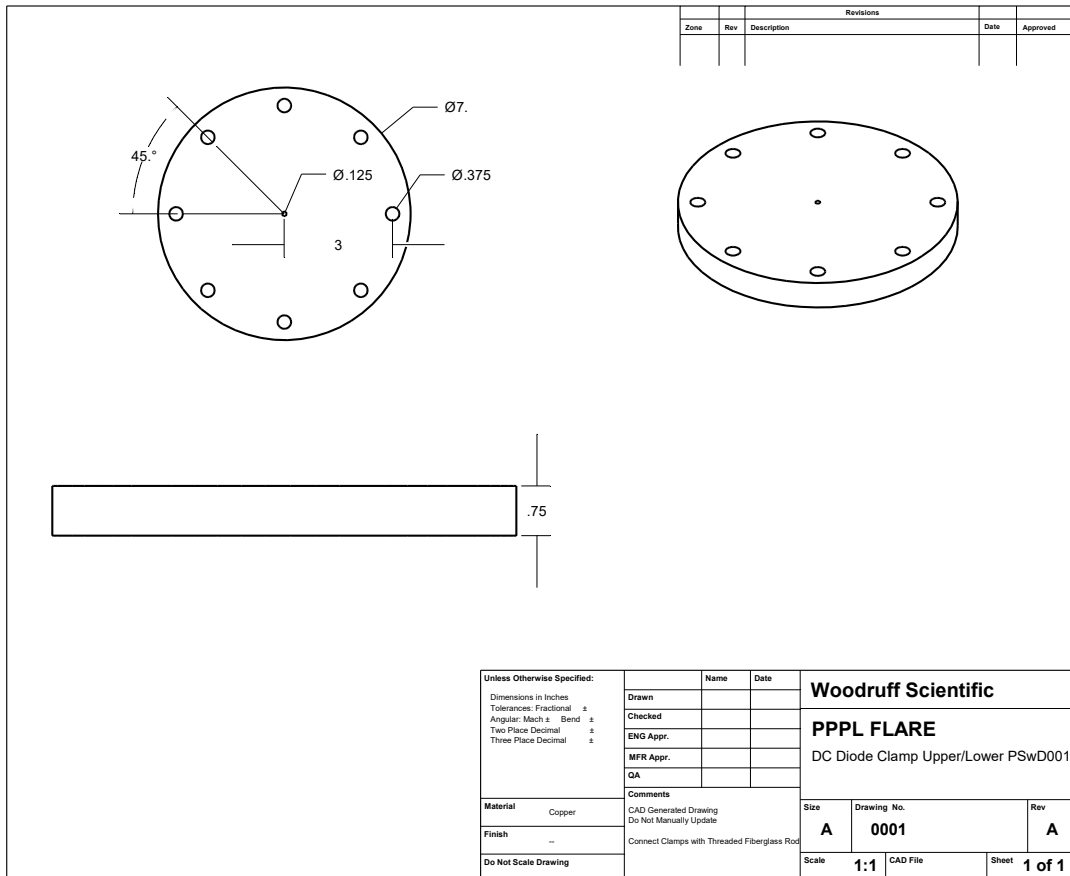

Figure 15: Diode Clamp Upper/Lower

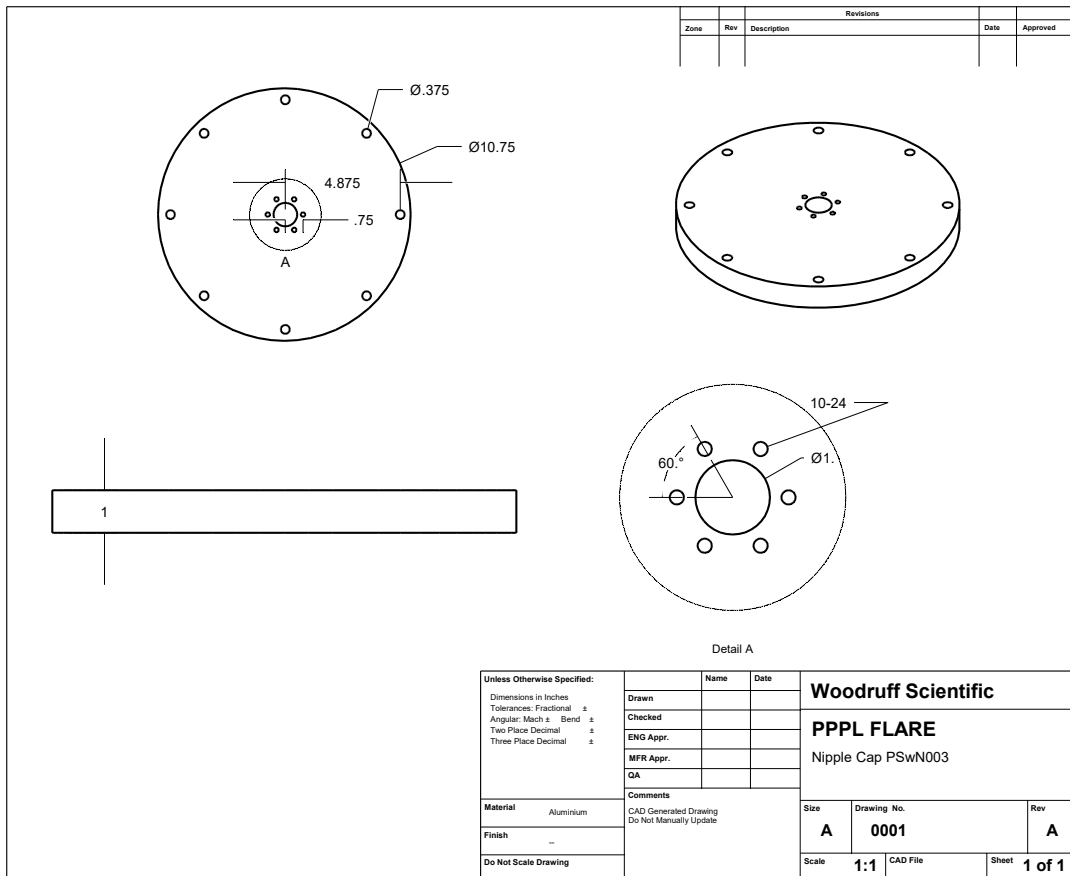
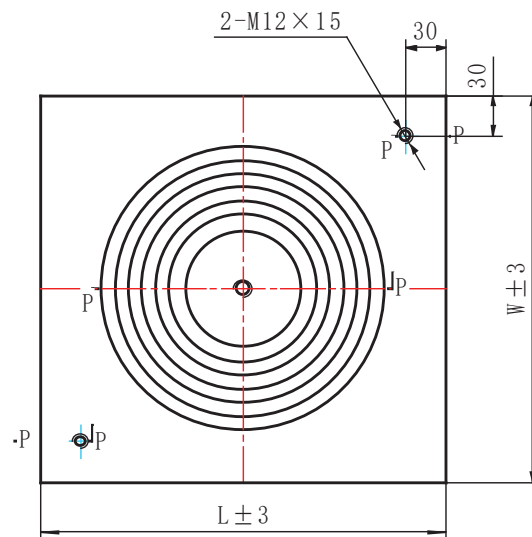
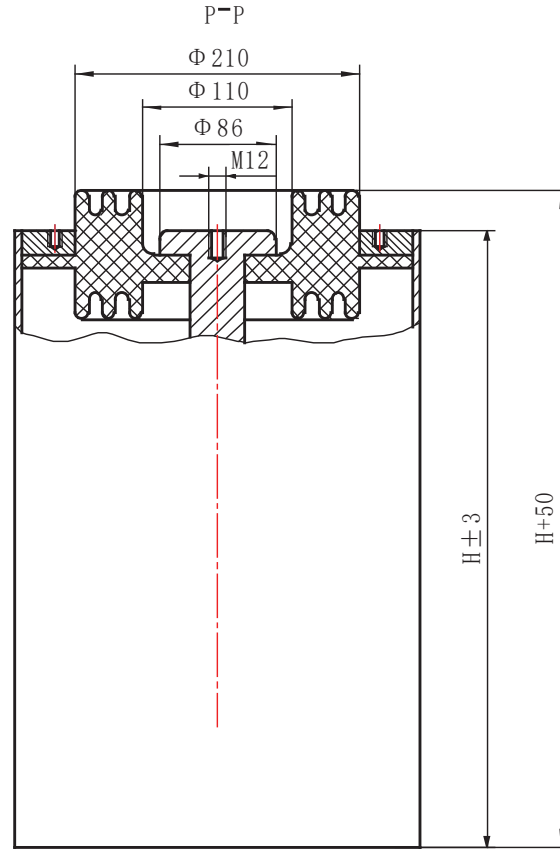

Figure 16: Nipple Cap

## HDCT 60kV 2.8 $\mu$ F Pulse Capacitor

Type		HDCT
Rated voltage	$U_{NDC}$	60kVDC
Rated capacitance	$C_N$	2.8 $\mu$ F
Capacitance tolerance		$\pm 5.0\%$
Rated Discharge Current	$I_p$	50kA
Max Discharge Current (system fault)	$\hat{i}$	60kA
Rated Discharge Voltage Reversal	%	80%
Self inductance	$L_S$	< 50 nH
Int. series resistance	$R_S$	< 10m $\Omega$
Loss factor	$\tan\delta$	< $1.0 \times 10^{-3}$ / 100 Hz
Life Expectancy (90 % survival)		500,000 discharges
Operating temperature	$\Theta_{min}/ max$	-40°C / +70 °C
Technology		Metalized Polypropylene film, dry type, SH
Dimensions(mm <sup>3</sup> )		320 $\times$ 320 $\times$ 530



Specification	L (mm)	W (mm)	H (mm)
60kV 2.8 $\mu$ F	320	320	530

## HDCT 60kV 7.5 $\mu$ F Pulse Capacitor

Type		HDCT
Rated voltage	$U_{NDC}$	60kVDC
Rated capacitance	$C_N$	7.5 $\mu$ F
Capacitance tolerance		$\pm 5.0\%$
Rated Discharge Current	$I_p$	50kA
Max Discharge Current (system fault)	$\hat{i}$	80kA
Rated Discharge Voltage Reversal	%	80%
Self inductance	$L_S$	< 50 nH
Int. series resistance	$R_S$	< 10m $\Omega$
Loss factor	$\tan\delta$	< $1.0 \times 10^{-3}$ / 100 Hz
Life Expectancy (90 % survival)		500,000 discharges
Operating temperature	$\Theta_{min/ max}$	-40 $^{\circ}$ C / +70 $^{\circ}$ C
Technology		Metalized Polypropylene film, dry type, SH
Dimensions(mm <sup>3</sup> )		528 $\times$ 320 $\times$ 775

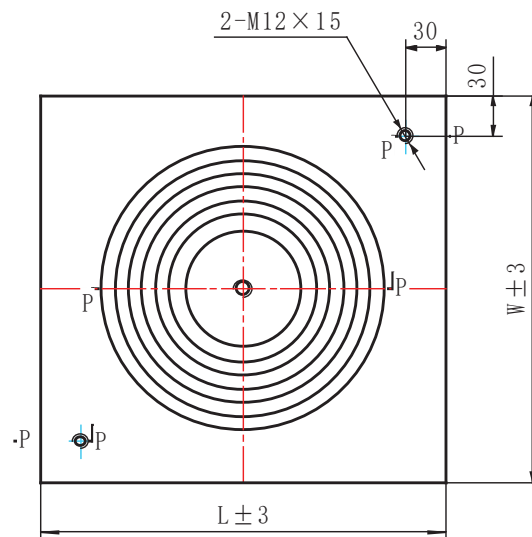
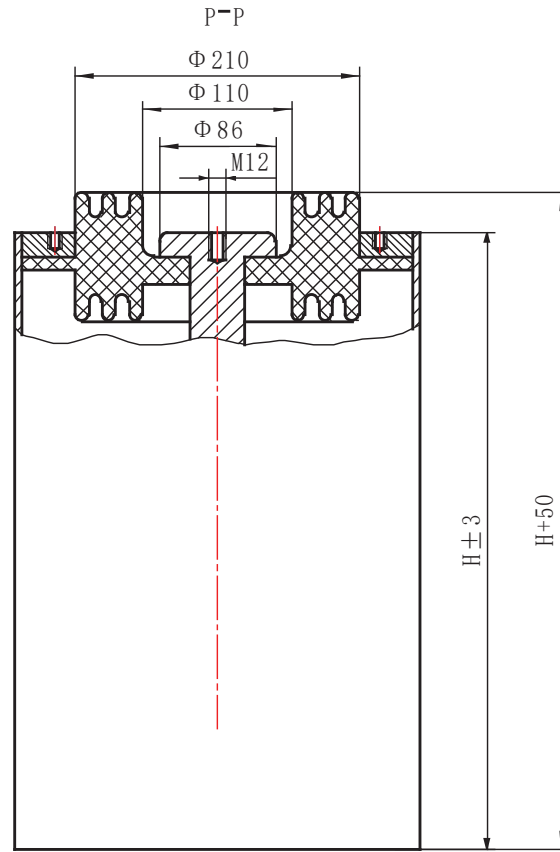

Specification	L (mm)	W (mm)	H (mm)
60kV 7.5 $\mu$ F	528	320	775

#### 4. Warranty

All valves manufactured by "Pulsed Technologies Co. Ltd." (The Manufacturer) are guaranteed to be free of defects in workmanship, materials and construction and are designed to give satisfactory service when used under normal operating conditions. The Manufacturer guarantees conformity of thyratrons to the parameters specified in the appropriate clause of the thyratrons' certificate within a period of 12 months from the date of delivery, confirmed by shipping documents, or within a minimum operating time equal to  $5 \times 10^4$  pulses, either within a filament life of 1000 hours whichever comes first. The above conditions should be considered provided the thyratrons are treated in accordance with the technical parameters stated in the appropriate clause of the thyratrons' certificate (p.1.1).

For valves failing before expiration of operating time  $10^4$  pulses, a valve may at the option of Manufacturer be replaced free of charge or credited in full, provided that the filament life guaranteed has not expired. For valves failing with a filament life in excess of the initial period up to operating time  $10^4$  pulses, but less than the total warranty minimum operating life, replacement or credit will be given on pro rata basis determine by the ratio of the unrealised portion of the warranted operating life to the total warranty minimum operating life. The operating life is considered to start when the valve is first put into service, even though it may subsequently be removed and held as a spare.

**Conditions of Warranty.** The warranty is valid only if the following conditions are met :

1. The valve is supplied direct from the Manufacturer or via an agency, representative or other selling medium authorized by Manufacturer.
2. The valve is operated within the published minimum and maximum ratings, provided that safety devices for protection against overcurrent in terms of average current are fitted and operation time counter is used.
3. The valve is not subjected to any negligence in use, storage, transportation or handling.
4. The decision of Manufacturer on the cause of failure and on the value and form of any applicable allowances is accepted by the customer.
5. Right of access to equipment for the purpose of checking operating conditions is granted to any representative of Manufacturer where Manufacturer may so require.
6. Manufacturer is notified within 30 days of the valve failure.
7. The valve is withdrawn from service as soon as possible after the failure is alleged to have occurred.

**5. Claims Information.** In case of a premature failure of a thyatron it should be returned to the Manufacturer within 30 days together with the Certificate stating the following information:

Storage time \_\_\_\_\_  
Date of putting into operation \_\_\_\_\_  
Date of failure \_\_\_\_\_  
Specifications of a mode of operation \_\_\_\_\_

Operating time in the specified mode \_\_\_\_\_ of hours (total switched charge).  
information about operating conditions, cause of failure.

The reasons for removal of a thyatron from operation \_\_\_\_\_  
The items of information are filled \_\_\_\_\_

(Date, signature)

In case of absence of the filled passport the claim is not accepted.

Individual № \_\_\_\_\_, Manufacturing date \_\_\_\_\_

Address: "Pulsed Technologies Co. Ltd." 5, Yablochkova Str., 390023 Ryazan, Russia.

Tel./fax: +7 (4912) 24-9217, tel.: +7(4912)24-0519,

E-mail: [pulsetech@mail.ru](mailto:pulsetech@mail.ru), [info@pulsetech.ru](mailto:info@pulsetech.ru)

Web site: <http://www.pulsetech.ru>



## TDI4-100k/75H THYRATRON

### Certificate. Certificate of Quality.

TDI4-100k/75H thyatron (Copper Arc Thyatron, Grounded Grid Thyatron) is intended for use as a switch tube in pulse circuits of capacitive storages with sub-microsecond and microsecond pulse duration. The thyatron is manufactured in conformity with technical conditions KBФM.433.212.026TY for use in various installations for domestic as well as export delivery.

#### 1. Basic Technical Data.

Pulse thyatron has a ceramic/metal envelope, three high-voltage sections, filled with hydrogen (deuterium) as buffer gas at  $20 \div 60$  Pa in operational mode only. Semiconductor igniter is used to trigger the switch. Special dielectric coating protects internal surface of the envelope against damage in cases when anode reverse voltage achieves 100% of forward voltage. The tube is environmental-friendly product, has internal shield for minimization of X-Ray emission from the region of anode. The double-ended thyatron TDI4-100k/75D is a bi-directional switch. In TDI4-100k/75D variant the thyatron comprises hollow anode incorporating an extra igniter and is used, for example, for operation in modes with oscillating current, as well as for triggering both from cathode and anode part. Design of the thyatron is covered by Russian Federation patents №2300157, 2418339, International Patents PCT/RU2005/000298, PCT/RU2011/000038 and US Patent No.7,825,595 B2.

#### 1.1. Electrical Parameters in Optimum Operation Mode

Parameter	Value	Fact. value
Forward anode voltage, $kV$	5÷70	
Peak forward anode current, $kA$	50	
Anode current 1st half-wave width, $\mu s$	5.0	
Pulse repetition rate, $Hz$	0.5	
Reservoir heater (heater R) voltage, $V$ , (not less/not more)	3.0/7.0	
Heater R current (at nominal $U_{HR} = \quad V$ ), $A$	2.5	
Heater G current (at nominal $U_{HG} = \quad V$ ), $A$	2.5	
Peak open circuit trigger voltage, $kV$ , (not less/not more)	4.0/6.0	
Peak trigger current, $A$ , (not less/not more)	80/200	
Trigger current pulse duration, $\mu s$	2÷4	
Tube warm-up time, <i>minutes</i>	5.0	

#### 1.2. Absolute ratings (maximus, nonsimultaneous)\*

Parameter	Value
Peak forward anode voltage, $kV$ (Notes 1, 2,3)	2÷80
Peak reverse anode voltage, $kV$ (Notes 3)	50
Peak forward anode current, $I_b$ , $kA$	100
Peak reverse anode current, $I_{bx}$ , $kA$ (Note 4)	up to 95% of $I_b$
Maximum anode current rise rate, $A/s$ (Note 5)	$1 \cdot 10^{12}$
Anode current pulse duration, $\mu s$	0.1÷100.0
Pulse repetition rate, $f$ , $Hz$ (Note 6)	300
Switched energy per shot, $J$	20 000
Anode Dissipation Factor ( $P_b = V \times A \times pps$ ) (Note 6)	$70 \cdot 10^9$
Root mean square current, $RMS = \sqrt{I_b \times i_b}$ ( $i_b = C \cdot U \cdot f$ ) (Note 6)	700
Peak open circuit trigger voltage, $kV$ , (not less/not more)	4.0/10.0
Peak trigger current, $A$ , (not less/not more)	80/250
Rate of rise of ignition voltage pulse, $kV/\mu s$ , not less	5.0
Time jitter, $ns$ (Note 7)	3

Notes \*Operation of the thyatron when two or more parameters listed in p.1.1 are exceeded simultaneously may be permitted only upon agreement with the Manufacturer.

<sup>1)</sup> Immerse the tube into SF<sub>6</sub>, N<sub>2</sub> or oil when operating at voltage over 45  $kV$ .



- <sup>2)</sup> The dwell time at the peak anode voltage should be minimized in order to minimize pre-firing. For operation at the rated peak forward anode current, the dwell time must be less than 0.5 of pulse period, but must not exceed 1 millisecond.
- <sup>3)</sup> After the thyatron anode current ceases and before voltage is reapplied to anode, the anode voltage must be kept between minus (100 -5000) Volts for at least 100  $\mu$ s for working gas deionization.
- <sup>4)</sup> For hollow anode variants TD14-100k/75H and. TD14-100k/75D. For TD14-100k/75 reverse current <10% of  $I_b$ .
- <sup>5)</sup> The ultimate value depends on the external circuit parameters.
- <sup>6)</sup>  $P_b > 3 \cdot 10^6$  and RMS >80 can be achieved in burst mode only ( $i_b = C U_{af}$  – average current, C – switching capacitance). Burst and pause durations must be agreed with the Manufacturer.
- <sup>7)</sup> High-rate of rise of trigger voltage pulse trigger system by a cable pulse generator (fig.2).

1.3. Maximum overall dimensions ( $\varnothing_{\text{cathode flange}} \times H_{\text{max}}$ ), mm - 152×160. Weight - not more than 4.2 kg.  
 1.4. Lifetime expectancy specified in item 1.1 -  $10^6$  Coulomb.

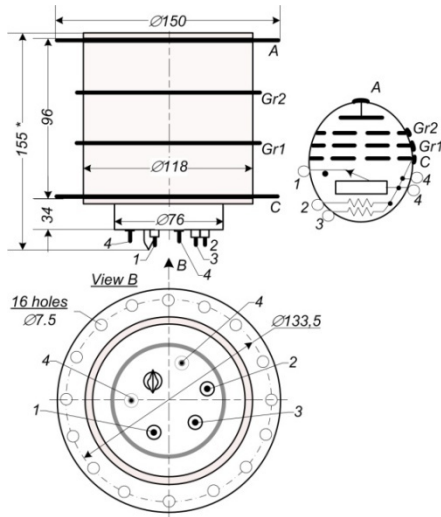

## 2. Diagram of electrode connections

- A - Hollow Anode;  
 Gr1 - Gradient grid 1;  
 Gr2 - Gradient grid 2;  
 C - Cathode, igniter terminal (+);  
 1 - trigger negative pulse;  
 2 - Heater R (cold  $R_{res} \sim 1\Omega$ );  
 3 - Heater G (cold  $R_g \sim 1\Omega$ );  
 4 - cathode terminals (for driver common only).

**ATTENTION!** It is required in all circuits to carefully observe polarity of ignition voltage applied to the appropriate pins of the igniter and to provide symmetry of current pick-off from cathode and anode flanges relative to the axis of the device: (J.Slough, C.Pihl, V.D.Bochkov, et al. «Prospective Pulsed Power Applications Of Pseudospark Switches», 17th IEEE International Pulsed Power Conference, 2009, Washington, DC).

The thyratrons must be handled carefully in order to prevent mechanical effect onto the pins 1, 2, 3 exceeding 3 kgs in an axial direction and 1kgs in direction perpendicular to the axes. It is strictly forbidden to hit the valve pins.

## 3. Operation Guidelines

- 3.1. Trigger negative signal must be applied to the pin 1 of the thyatron. Resistance of igniter within warranty period is  $5k\Omega \div 200 M\Omega$ .
- 3.2. For reliable operation of the thyratrons use pulse driver PB-3D or PB-3DV, providing powering of auxiliary electrodes in conformity with thyatron ratings. The driver is designed and manufactured by Pulsed Technologies Ltd.
- 3.3. Switching sequence: a) connect heater voltage power supply output to the appropriate pin; b) allow the heater to warm up for not less than 5 minutes; c) apply pulse trigger voltage to the igniter, then apply anode voltage (30-50% of maximum level) and smoothly increase the anode voltage up to the operating level. It is permitted to simultaneously switch on heater and trigger voltages.
- 3.4. The maximum-allowed temperature of cathode, anode and grid flanges is  $+100^\circ\text{C}$ . If exceeded, a forced air or liquid (oil) cooling must be used. Air flow rate is to be not less than  $2.5 \text{ m}^3/\text{min}$  at  $25^\circ\text{C} \pm 10^\circ\text{C}$  of thermofoir.
- 3.5. When switching off, first switch off anode voltage, then all the rest voltages. It is permitted to switch off all voltages simultaneously.
- 3.6. For ensuring guaranteed period of operation in modes different from those specified in p.1.1 it is necessary to select voltage of the heater subject to conditions of thyatron performance. For this purpose (with nominal load) gradually increase hydrogen reservoir (R) heater voltage in  $0.1 \div 0.3 \text{ V}$  increments from the value specified in the certificate staying at each value for 2÷3 minutes before appearance of signs of unstable operation (transition to higher frequency or to continuous discharge). In case of the signs appearance, switch off anode voltage, reduce heater R voltage by  $0.1 \div 0.2 \text{ V}$  and

within a minute switch on anode voltage and maintain it for 5-10 minutes. At steady operation fix the given heater voltage. Henceforth it is recommended to repeat this procedure after every total  $10^4 \text{ C}$  of operation.

3.7. After transportation or a long period of storage a regulated seasoning under operation conditions within not less than 30 minutes is required. When conditioning the thyatron, anode voltage must be raised gradually in  $3 \div 5 \text{ kV}$  increments from a minimum peak voltage of  $10 \div 15 \text{ kV}$  up to peak forward anode voltage. The criteria of successful conditioning at each step will be absence of misfires within 3-5 minutes.

### Recommended Circuit for Ignition Pulse Generator

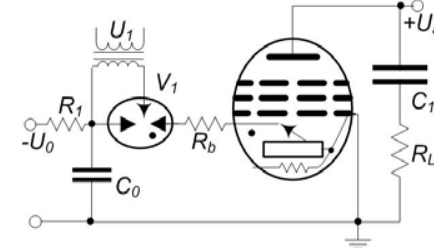

Fig.1. Electrical schematic of a triggered spark gap based trigger pulsed driver.

$V_1$ - RU83-6 Triggered Spark Gap.

$R_1=10k\Omega$ ,  $R_b=(0 \div 50)\Omega$ ,

$C_0=(0.01 \div 0.2) \mu\text{F}$ ,

### Version of Ignition Pulse Generators

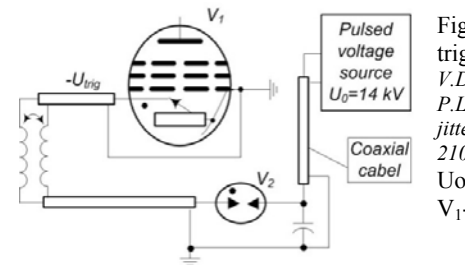

Fig.2. Electrical schematic of low-jitter (<5 ns), low-energy, trigger system cable pulse generator. (V.A.Gribkov, M.Scholz, V.D.Bochkov, A.V.Dubrovsky, R.Miklaszewski, L.Karpinski, S.Lee, P.Lee, Pseudosparks in nanosecond range of its operation: firing, jitter, and disconnection, Journal of Physics D: Appl. Phys. 37, 2004, 2107–2111.)

$U_0=8 \div 12 \text{ kV}$ ,  $C_1=(0.01 \div 0.2) \mu\text{F}$

$V_1$ - spark gap; cable length ~ 6 m;

Fig. 3. Principal circuit of gradient grid feed.

$C_1=(0.3 \div 0.5) \text{ nF}$ ,  $R_1=(5 \div 20) M\Omega$ ,

$R_2=470\Omega$

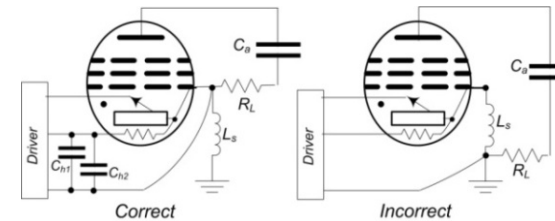
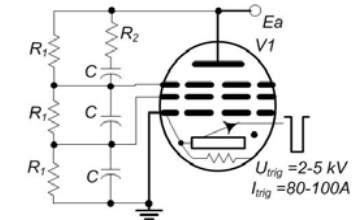

Fig.4. Please make sure that voltage jumps (stray voltage)  $U_s=L_s \cdot di/dt$  in ground circuit should be minimized. For that heating voltage cable must be connected to the thyatron connectors directly. Also load circuit must be connected right to the thyatron cathode and equipment case directly. Cathode of the tube

must be connected with equipment case by a minimum length cable (stray inductance  $L_s \rightarrow 0$ ).

$C_1, C_2$ : Reservoir protection capacitors with a voltage rating  $> 500 \text{ V}$ ;  
 $C_1 = 1000 \text{ pF}$  low inductance (e.g. ceramic),  $C_2 = 1 \mu\text{F}$  (e.g. polycarbonate).  
 Components  $C_1, C_2$  should be mounted as close to the tube as possible.

**DIODE ACTION = 0.5 E<sup>6</sup>I<sup>2</sup>Sec**

**VRE-3005      5 KV**

**VRE-3010      10 KV**

**VRE-3015      15 KV**

**DIODE ACTION = 1.9 E<sup>6</sup>I<sup>2</sup>Sec**

**VRE-5005      5 KV**

**VRE-5010      10 KV**

**VRE-5015      15 KV**

**Plus : unlimited series without external components**

**Plus : unlimited parallel without additional matching**

**VR ELECTRONICS CO. LTD**  
**HALF SINE Action**

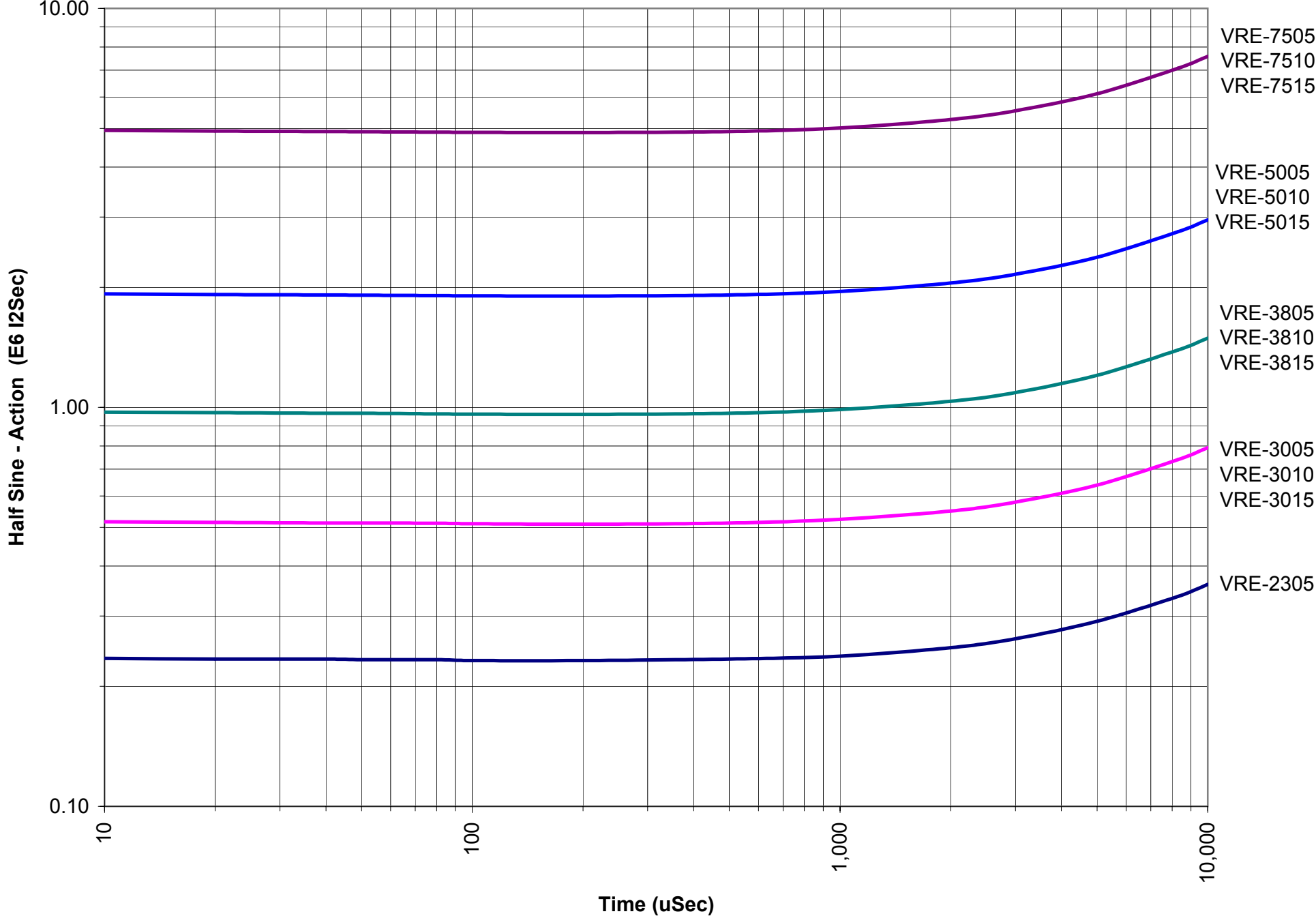

# VR ELECTRONICS CO. LTD

## HALF SINE Peak Current

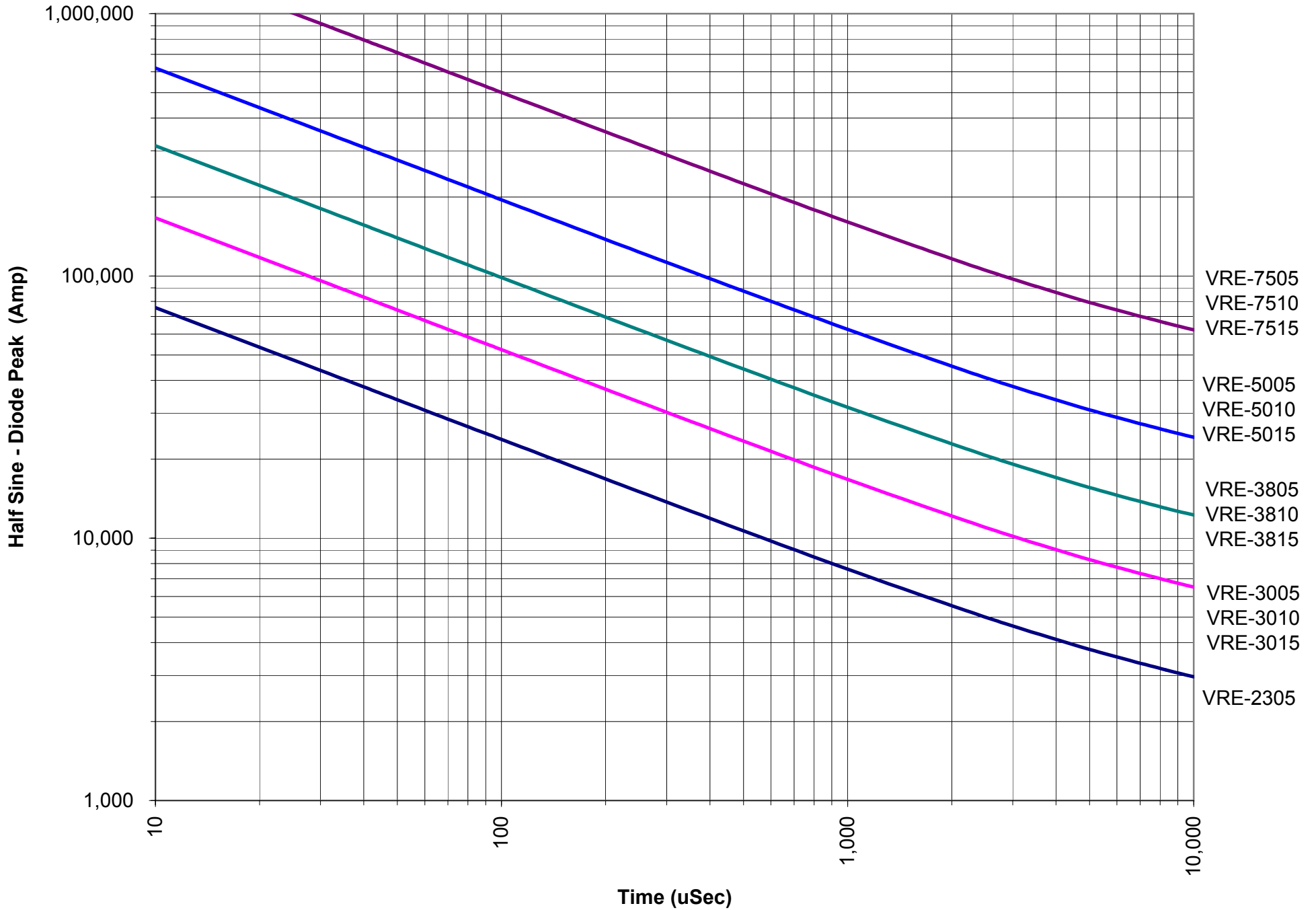

VR ELECTRONICS CO. LTD  
L/R Action

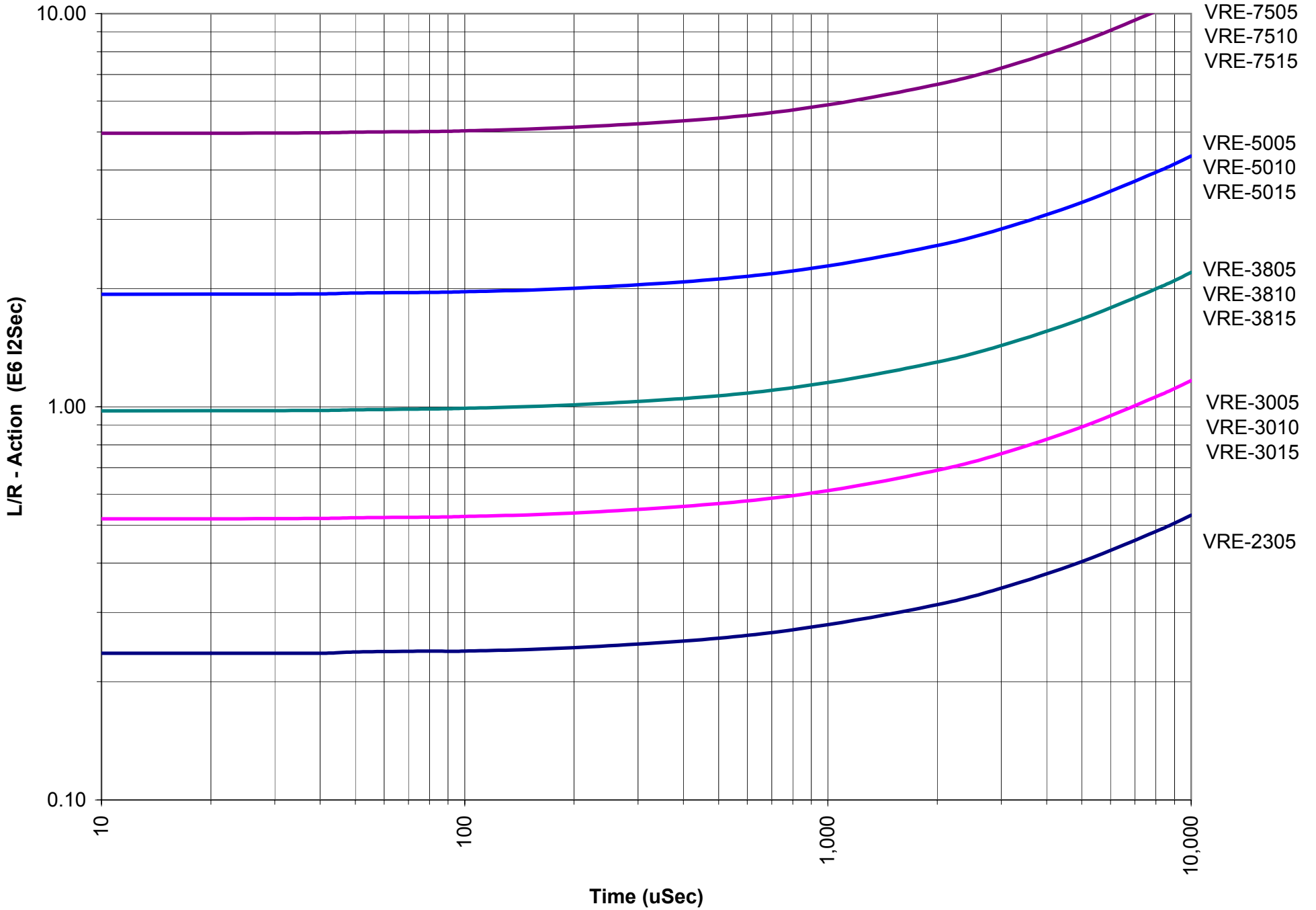

VR ELECTRONICS CO. LTD  
L/R Peak Current

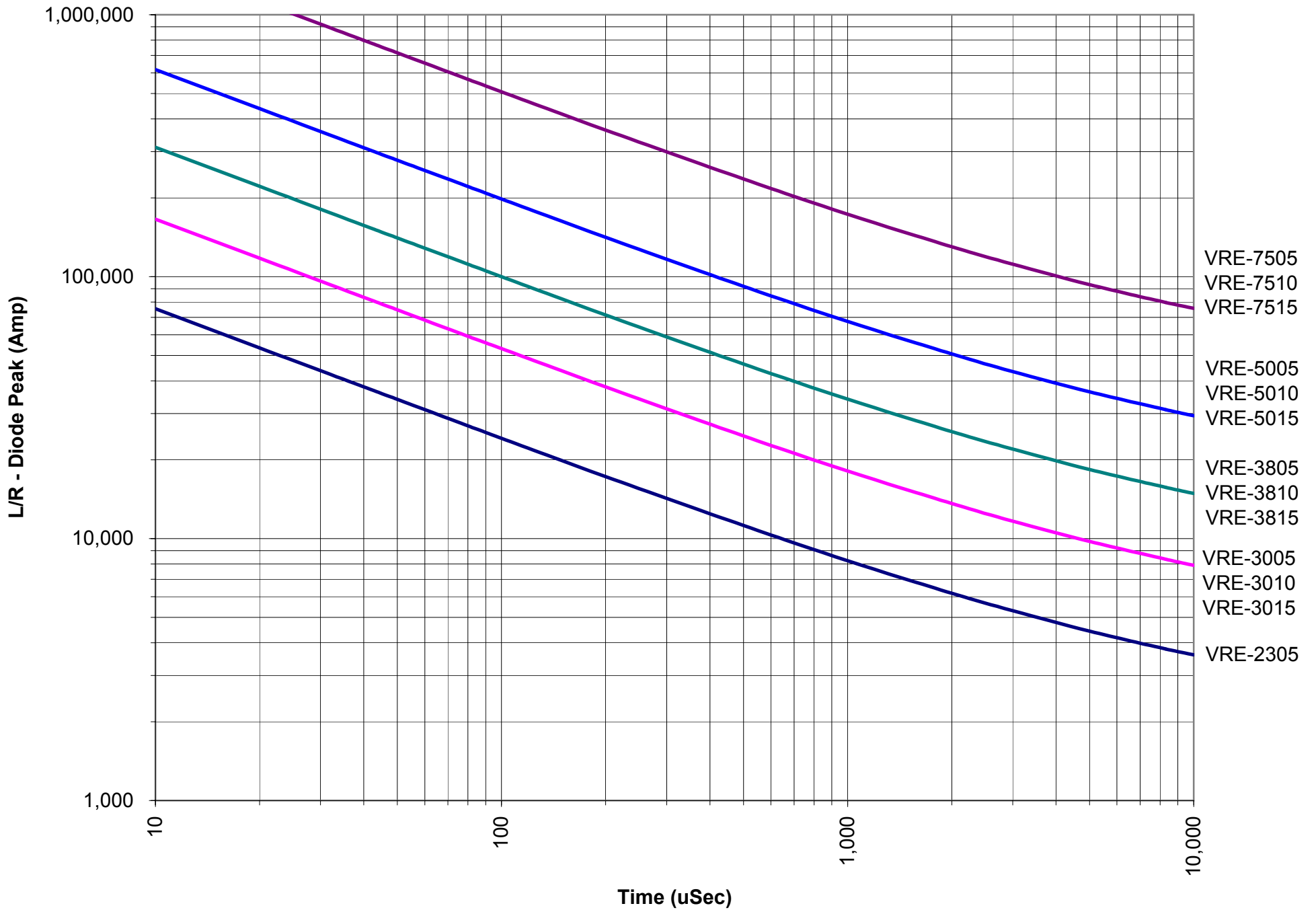

# PACKAGE OUTLINE

VRE-3005 , 5 KV (V<sub>rrm</sub>)

V<sub>rrm</sub> = max peak repetitive and DC voltage

Holes in both electrode pole faces  
Ø3.56 (0.140) x 2.04 (0.080) deep

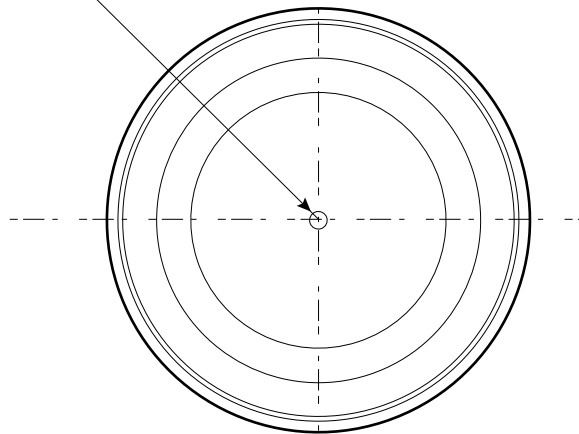

Cathode

Ø42 (1.654) max

Ø25 (0.984) nom.

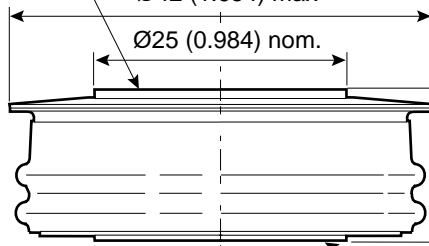

15.37 (0.605)  
14.0 (0.551)



Ø25 (0.984) nom.

Anode

Nominal weight: 85g (0.19 lb)

Clamping force: 8.9 kN (2,000 lb)

All dimensions are in mm (inches)

# PACKAGE OUTLINE

VRE-3010 , 10 KV ( $V_{rrm}$ )

VRE-3015 , 15 KV ( $V_{rrm}$ )

$V_{rrm}$  = max peak repetitive and DC voltage

Holes in both electrode pole faces  
 $\varnothing 3.56$  (0.140) x 2.04 (0.080) deep

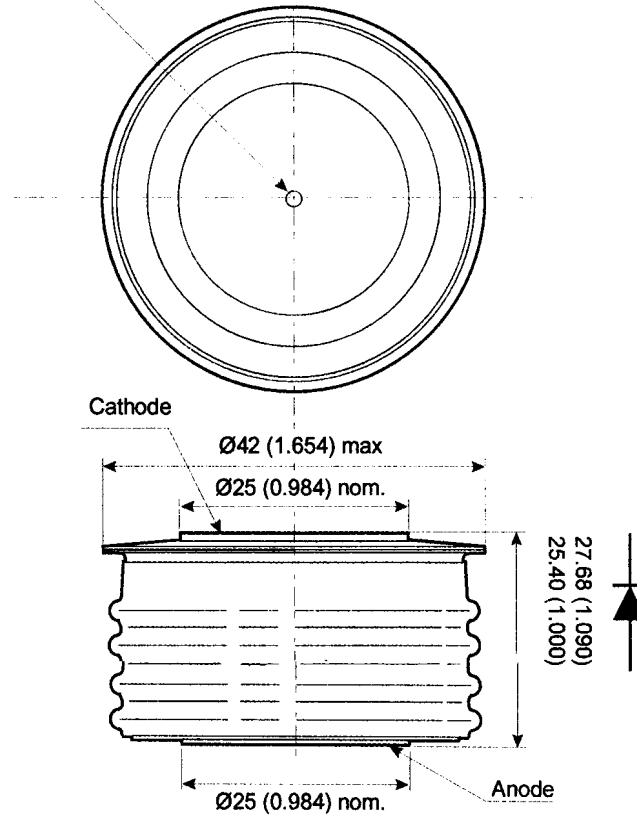

Nominal weight: 155g (0.34 lb)

Clamping force: 8.9 kN (2,000 lb)

All dimensions are in mm (inches)



# PACKAGE OUTLINE

VRE-5005 , 5 KV (V<sub>rrm</sub>)

VRE-5010 , 10 KV (V<sub>rrm</sub>)

VRE-5015 , 15 KV (V<sub>rrm</sub>)

V<sub>rrm</sub> = max peak repetitive and DC voltage

Holes in both electrode pole faces

Ø 3.56 (0.140) x 2.04 (0.080) deep

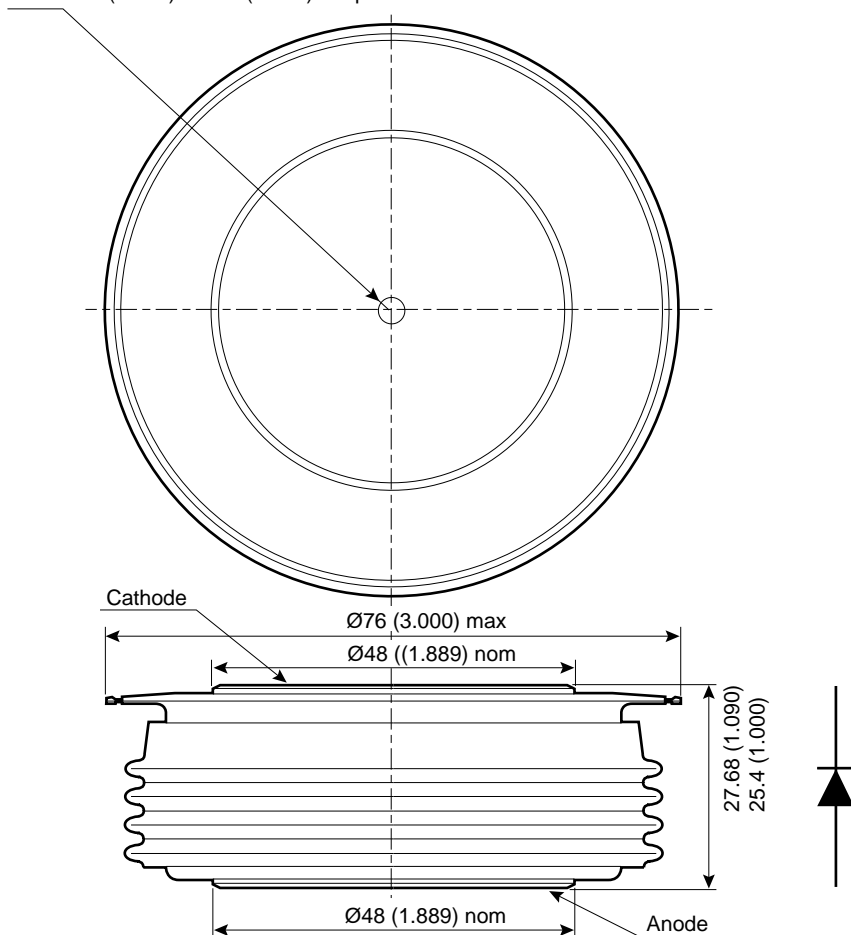

Nominal weight: 485g (1.07 lb)  
Clamping force: 22 kN (5,000 lb) ± 10%

## JEDEC outline DO-200AC

All dimensions in mm (inches)

# HIGH POWER 8C-30C SERIES

## 8kV to 30kV High Voltage Cap-Charging Supplies

This High Power line of high-voltage regulated DC to DC converters is an extension of the C Series, directly addressing the high power density needs of >30 watt applications. High Power 8C - 30C units provide up to 60/125/250 watts. This high power density is especially suited to high-energy systems with large capacitances, fast repetition rates, or high continuous-DC-power requirements. See Application Note 10 for more changing information. Typical applications for the High Power 8C-30C Series include the following: laser, cap-charger, pulse generators, Q-switch, and TDR test equipment.

- 7 models from 0 to 8kV through 0 to 30kV
- 60, 125, or 250 watts of output power
- Maximum Iout capability down to 0 Volts
- Maximum Iout during charge/rise time
- Output short-circuit protection
- Very fast rise with very low overshoot



- High efficiency
- High power to voltage density
- Very low profile
- Output current & voltage monitors
- >200,000 hour MTBF @65°C
- Fixed-frequency, low-stored-energy design
- UL/cUL Recognized Component; CE Mark (LVD & RoHS)

PARAMETER	CONDITIONS	ALL TYPES																				UNITS																
<b>INPUT</b>		<b>ALL TYPES</b>																																				
Voltage Range	Full Power	+ 23 to 30																				VDC																
Voltage Range	Derated Power Range	60W, 125W: + 11 to 30, 250W: 15-30																				VDC																
Current	Standby / Disable	< 40																				mA																
Current	No Load, Max Eout	8C to 15C < 500, 20C to 25C < 600																				mA																
Current	Max Load, Max Eout	60W: 3.25, 125W: 6.5, 250W: 13																				A																
AC Ripple Current	Nominal Input, Full Load	< 50																				mA p-p																
<b>OUTPUT</b>		<b>8C</b>					<b>10C</b>					<b>12C</b>					<b>15C</b>					<b>20C</b>					<b>25C</b>					<b>30C</b>						
Voltage Range	Nominal Input	0 to 8,000					0 to 10,000					0 to 12,000					0 to 15,000					0 to 20,000					0 to 25,000					0 to 30,000					VDC	
Power	Nominal Input, Max Eout	60	125	250	60	125	250	60	125	250	60	125	250	60	125	250	60	125	250	60	125	250	60	125	250	60	125	250	60	125	250	60	125	250	60	125	250	Watts
Current	Iout, Entire Output Voltage Range	7.5	15.5	31.2	6	12.5	25	5	10.5	20.8	4	8.3	16.7	3	6.25	12.5	2.4	5	10	2	4.17	8.33																mA
Current Scale Factor	Full Load	4.7	14.2	6.25	4.1	10.9	5	4.0	7.4	4.17	4.0	7.5	3.33	.65	.653	2.5	.65	.650	2	.65	.642	1.67															mAV	
Voltage Monitor Scaling		60W & 125W Models - 1000:1 ± 2% into 10MΩ; 250W Models - 10,000:1 ± 2%																				-																
Internal Capacitance	Capacitance / 95% Decay (50Meg Load)	4400/659	2200/330	1500/225	2933/439	1467/220	1500/225	2933/439	1467/220	750/112	2200/330	1100/165	750/112	1320/200	880/132	750/112	1100/165	733/110	500/75	825/125	550/85	500/75															pF/mS	
Ripple	Full Load, Max Eout	< 1%																				V p-p																
Rise Time	Max Iout, Various C Loads & Eout	Figure A																				-																
Storage Capacitance	Internal	4400	2200	1500	2933	1467	1500	2933	1467	750	2200	1100	750	1320	880	750	1100	733	500	825	550	500														pF		
Overshoot	C Load, 0 Eout to Full Eout	< 1%																				V pk																
Line Regulation	Nom. Input, Max Eout, Full Power	< 0.01%																				VDC																
Static Load Regulation	No Load to Full Load, Max Eout	< 0.01%																				VDC																
Stability	30 Min. warmup, per 8 hr/ per day	< 0.01% / < 0.02%																				VDC																
<b>PROGRAMMING &amp; CONTROLS</b>		<b>ALL TYPES</b>																																				
Input Impedance	Nominal Input	+ Output Models 1.1MΩ to GND, - Output Models 1.1MΩ to +5 Vref																				MΩ																
Adjust Resistance	Typical Potentiometer Values	10K to 100K (Pot across Vref. & Signal GND, Wiper to Adjust)																				Ω																
Adjust Logic	0 to +5 for +Out, +5 to 0 for - Out	+4.64 VDC for +Output or +0.36 for -Output = Nominal Eout																				-																
Output Voltage & Impedance	T=+25°C	+ 5.00VDC ± 1%, Zout = 464Ω ± 1%																				-																
Enable/Disable		0 to +0.8V Disable, +2.0 to 32 Enable (Default = Enable)																				VDC																
<b>ENVIRONMENTAL</b>		<b>ALL TYPES</b>																																				
Operating	Full Load, Max E out, Case Temperature	-40 to +65																				°C																
Coefficient	Over the Specified Temperature	±50 (±25 Optional)																				PPM/°C																
Thermal Shock	Mil-Std-810, Method 503-4, Proc. II	-40 to +65																				°C																
Storage	Non-Operating, Case Temp.	-55 to +105																				°C																
Humidity	All Conditions, Standard Package	0 to 95% non-condensing																				-																
Altitude	Standard Package, All Conditions	Sea Level through 70,000																				ft																
Shock	Mil-Std-810, Method 516.5, Proc. IV	20																				G's																
Vibration	Mil-Std-810, Method 514.5, Fig.514.5C-3	10																				G's																

Specifications subject to change without notice.

C = uF  
V = Volts  
I = mA  
T = mS

$$T = \frac{C \times V}{I}$$

C = uF  
V = kV  
I = mA  
F = Hz

$$I = C \times V \times F$$

C = uF  
V = kV  
I = mA  
F = Hz

$$F = \frac{I}{C \times V}$$

C = uF  
E² = kV  
J = Ws

$$J = \frac{C \times E^2}{2}$$

Figure A - Rise Time Formulas

NOTES: Capacitance must include HVPS internal Capacitance.



Making High Voltage Easier!®

Higher Service, Higher Performance, Higher Reliability

©2011, UltraVolt Inc. All rights reserved.

# HIGH POWER 8C-30C SERIES

8kV to 30kV High Voltage Cap-Charging Supplies

8C TO 15C - 60/125W

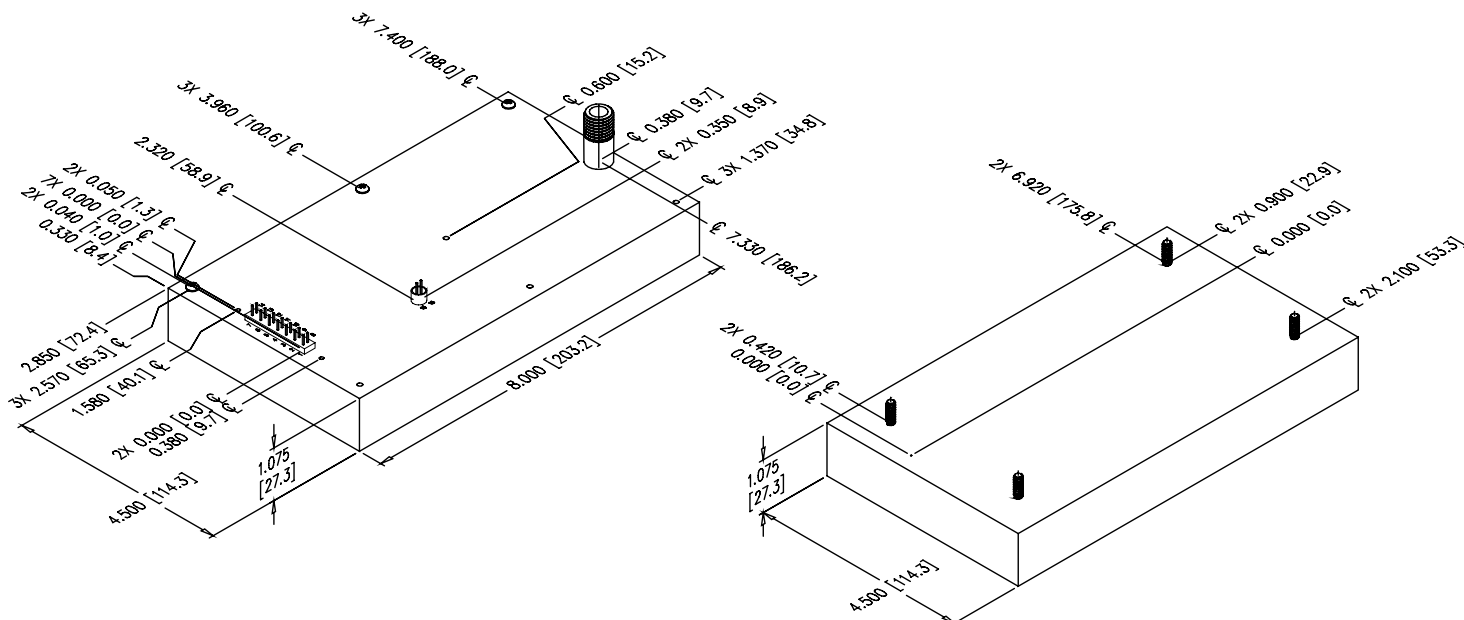

20C TO 30C - 60/125W

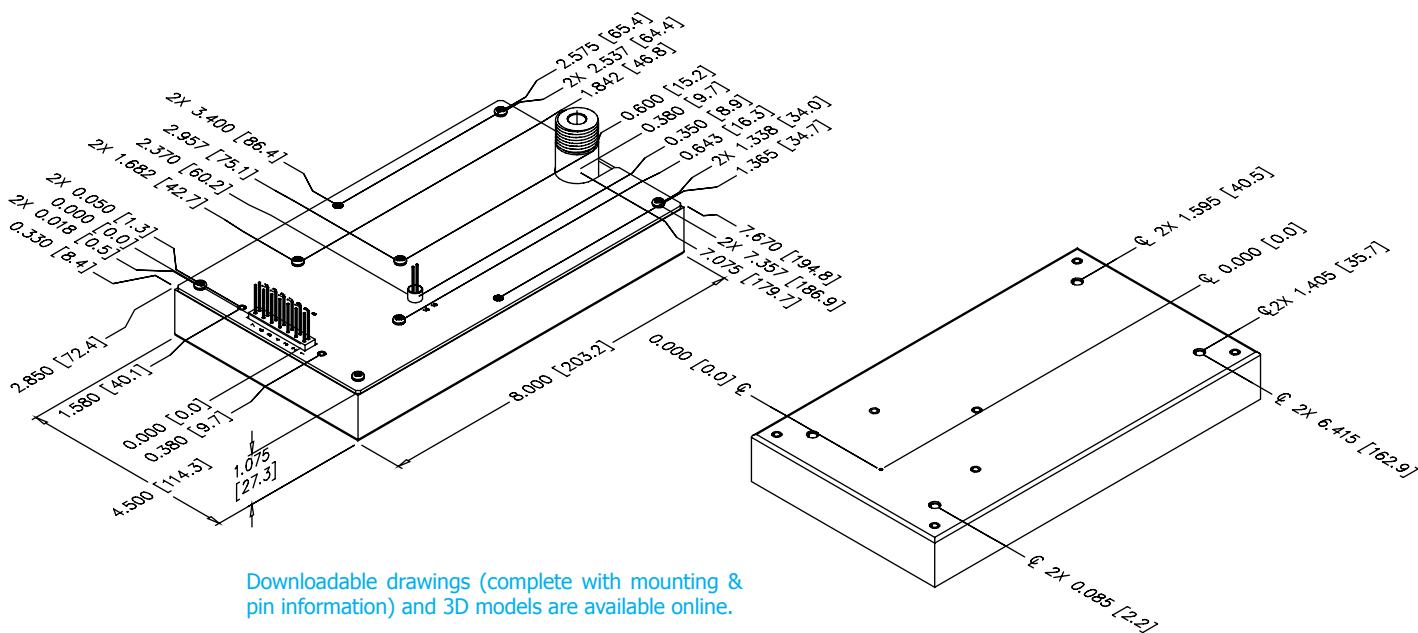

Downloadable drawings (complete with mounting & pin information) and 3D models are available online.



Making High Voltage Easier!®

1800 Ocean Avenue, Ronkonkoma, NY 11779  
Phone: 1-631-471-4444 Fax: 1-631-471-4696 www.ultravolt.com

# HIGH POWER 8C-30C SERIES

## 8kV to 30kV High Voltage Cap-Charging Supplies

### 8C TO 30C - 250W (PRELIMINARY)

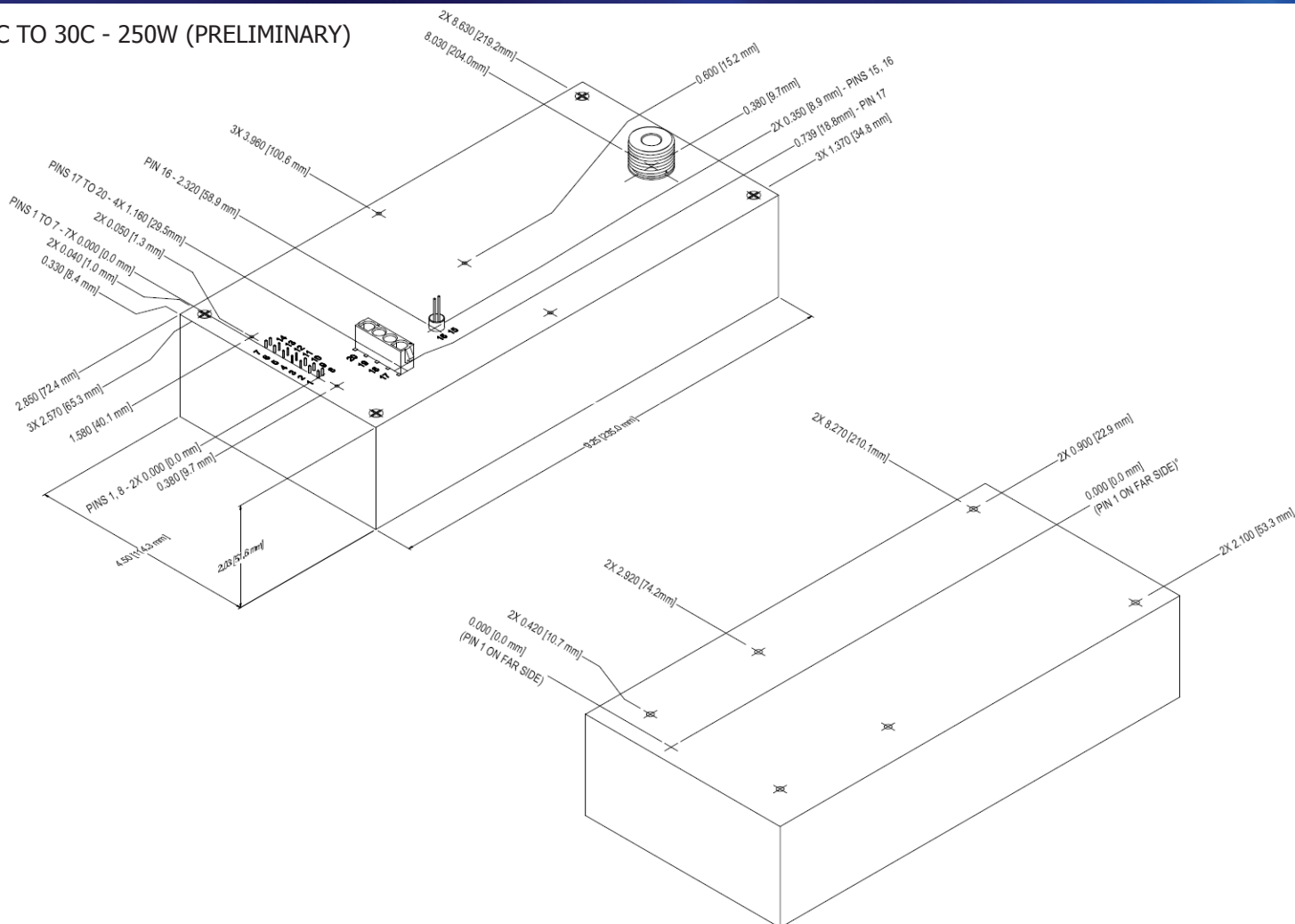

### CONSTRUCTION

Epoxy-filled Aluminum Box  
Chem film per MIL-A-8625 Type II (Anodizing)

### SIZE - 60 & 125W MODELS

Volume 38.7 in<sup>3</sup> (634cc)  
Weight 2.6 lbs. (1.18kg)

### SIZE - 250W MODELS

Volume 84.5 in<sup>3</sup> (1386cc)  
Weight 5.6 lbs. (2.54kg)

### TOLERANCE

Overall  $\pm 0.025''$  (0.64)  
Pin to Pin  $\pm 0.015''$  (0.38)  
Hole to hole location  $\pm 0.025''$  (0.64)

### PINS

Gold-plated 0.025 (0.64) sq.  
The center of the pins and mounting holes are located from the center of pin 1  
Pins 1 thru 14 spacing 0.100 (2.54) x 0.200 (5.08) on center, height from cover 0.280 (7.11) min  
Pins 15 and 16 spacing 0.100 (2.54) on center, height from cover 0.450 (11.43) min

### HV OUTPUT CONNECTION

Unit requires an LGH flying lead connector for proper operation:  
8C to 15C (60W & 125W Models) = CA-20KV-1000  
20C to 30C (60W & 125W Models) = CA-40KV-1000  
8C to 30C (250W Models) = CA-40KV-1000



Making High Voltage Easier!®

1800 Ocean Avenue, Ronkonkoma, NY 11779  
Phone: 1-631-471-4444 Fax: 1-631-471-4696 www.ultravolt.com

# HIGH POWER 8C-30C SERIES

## 8kV to 30kV High Voltage Cap-Charging Supplies

CONNECTIONS	
PIN	FUNCTION
1 & 8	Input-Power Ground Return
2 & 9	Positive Power Input
3	Iout Monitor
4	Enable/Disable
5	Signal Ground Return
6	Remote Adjust Input
7	+5VDC Reference Output
10	N/C (or Arc Detect option)
11, 12, & 13	N/C
14	Eout Monitor
15 & 16	HV Ground Return

All grounds joined internally. Power-supply mounting points isolated from internal grounds by >100kΩ, .01uF / 500V (Max).

ORDERING INFORMATION		
Type	0 to 8,000 VDC Output	8C
	0 to 10,000 VDC Output	10C
	0 to 12,000 VDC Output	12C
	0 to 15,000 VDC Output	15C
	0 to 20,000 VDC Output	20C
	0 to 25,000 VDC Output	25C
	0 to 30,000 VDC Output	30C
Input	24VDC Nominal	24
Polarity	Positive Output	-P
	Negative Output	-N
Power	60 Watts Output	60
	125 Watts Output	125
	250 Watts Output	250
Heat Sink	.400" High (sized to fit case)	-H
PCB Support	(5) 0.187" standoffs on top cover	-Z11
Enhanced Interface	5V Controls and Monitors	-I5
	10V Control and Monitors	-I10
Options	Arc Detect	-AD
	Arc Quench	-AQ
	25PPM Temperature Coefficient	-25PPM

Note: For more information on the enhanced interface options, download the [I5/I10 Option datasheet](#).

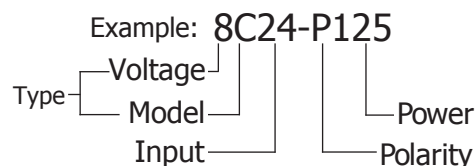

Popular accessories ordered with this product include CONN-KIT-HP, BR-7 and BR-8 mounting bracket kits and our full range of high voltage output connectors (see Accessories & Connectors datasheet).



Non-RoHS compliant units are available. Please contact the factory for more information.

Manufactured in USA



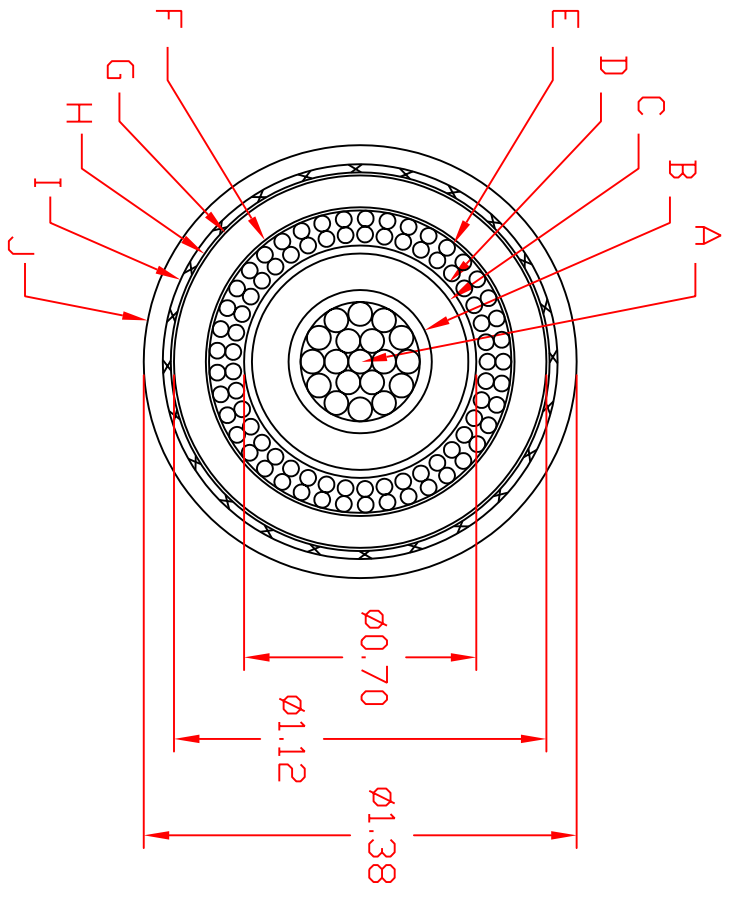

LEGEND

- A. #00 (19 X BARE COPPER COMPACTED), NOMINAL  $\phi$  0.376
- B. SEMICONDUCTING EPR,  $\phi$  0.42
- C. INSULATING EPR -  $\phi$  0.115 WALL TO  $\phi$  0.65
- D. SEMICONDUCTING EPR,  $\phi$  0.70
- E. OUTER CONDUCTOR, DOUBLE LAYER, 12 INCH LAY RHL INNER 41 X #18 AWG (19 X 30AWG T.C.) LHL OUTER 41 X #18 AWG (19 X 30AWG T.C.)
- F. SEMICON TAPE, 2" WIDE, 0.005 THK
- G. INSULATING LDHMMW POLYETHYLENE 0.100 WALL.
- H. SEMICON TAPE, 2" WIDE, 0.005 THK
- I. BRAID, #28 AWG T.C., 6 ENDS, 24 CARRIER, 70% COVERAGE.
- J. JACKET, PVC, BLACK, 0.06 WALL.

REVISIONS

REV	ECO NUMBER	APPD	DATE

THIS DOCUMENT AND THE INFORMATION CONTAINED IN IT ARE THE PROPERTY OF DIELECTRIC SCIENCES, INC AND SHALL NOT BE REPRODUCED OR COPIED OR USED AS THE BASIS FOR THE MANUFACTURE OF APPARATUS WITHOUT PERMISSION.

UNLESS OTHERWISE SPECIFIED

DIMENSIONS ARE IN INCHES TOLERANCE ON

DECIMALS .XX $\pm$ .01	ANGLES $\pm$
.XXX $\pm$ .005	

CONCENTRICITY .005 TIR  
REMOVE BURRS & SHARP EDGES  
ALL MACHINE SURFACES 125V



DRAWN	DATE
D. ABDULKY	14 JAN 16
CHECKED	DATE
APPROVED	DATE
MATERIAL	
FINISH	

<b>DIELECTRIC SCIENCES, INC</b>			
CHELMSFORD, MASSACHUSETTS 01824			
HV CABLE			
SIZE	FSCM NO.	DWG NO.	REV
A	50509	SK160114	1
SCALE		SHEET	OF

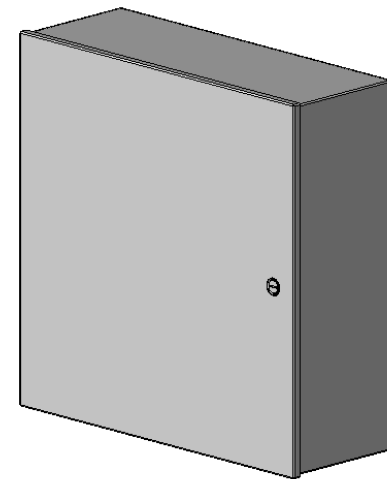
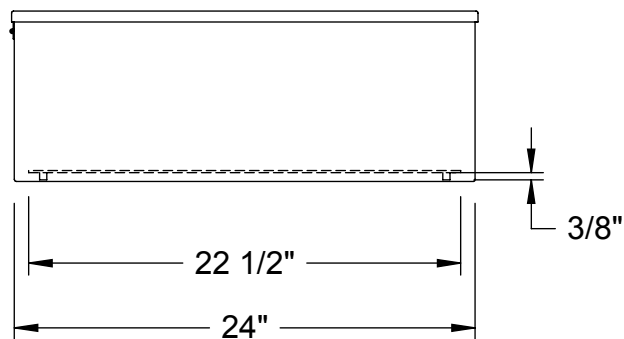
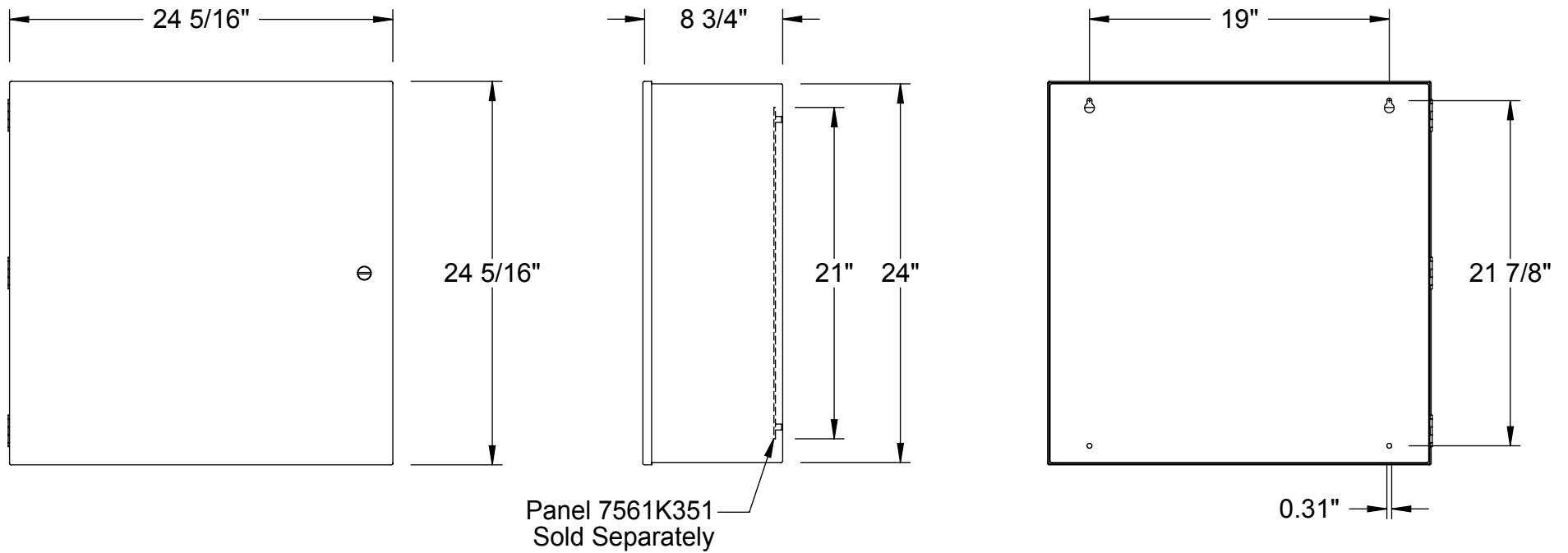

14-ga Steel (0.0747")

Approximate Internal Dimension: Ht. 23", Wd. 23", Dp. 8 1/8"

**McMASTER-CARR** CAD

PART  
NUMBER

**7561K64**

<http://www.mcmaster.com>  
© 2014 McMaster-Carr Supply Company

Indoor Steel  
Enclosure

Information in this drawing is provided for reference only.