

NO.	REVISION	BY	CH	SUP	APPROVED	DATE

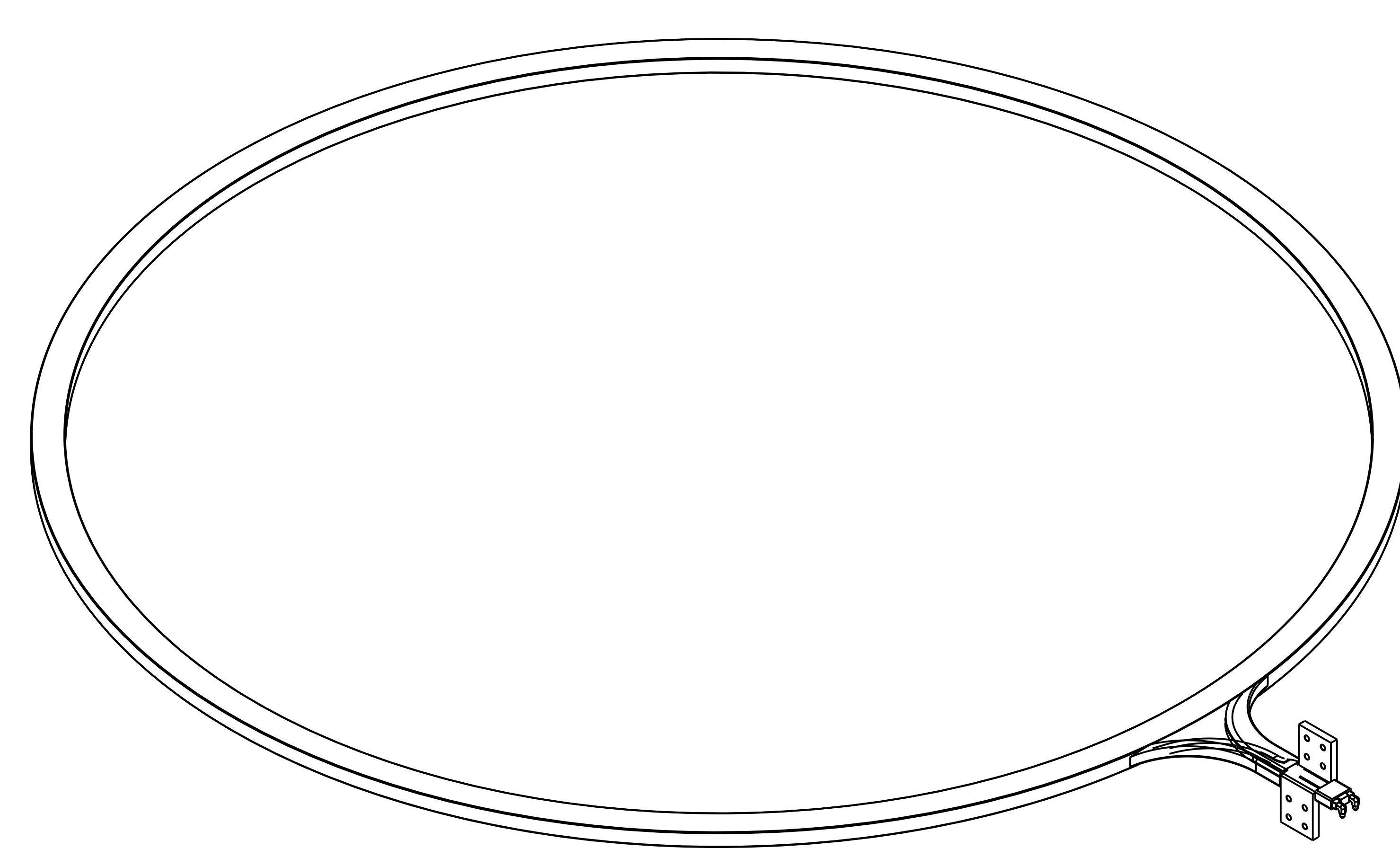

REFERENCE ISOMETRIC VIEW

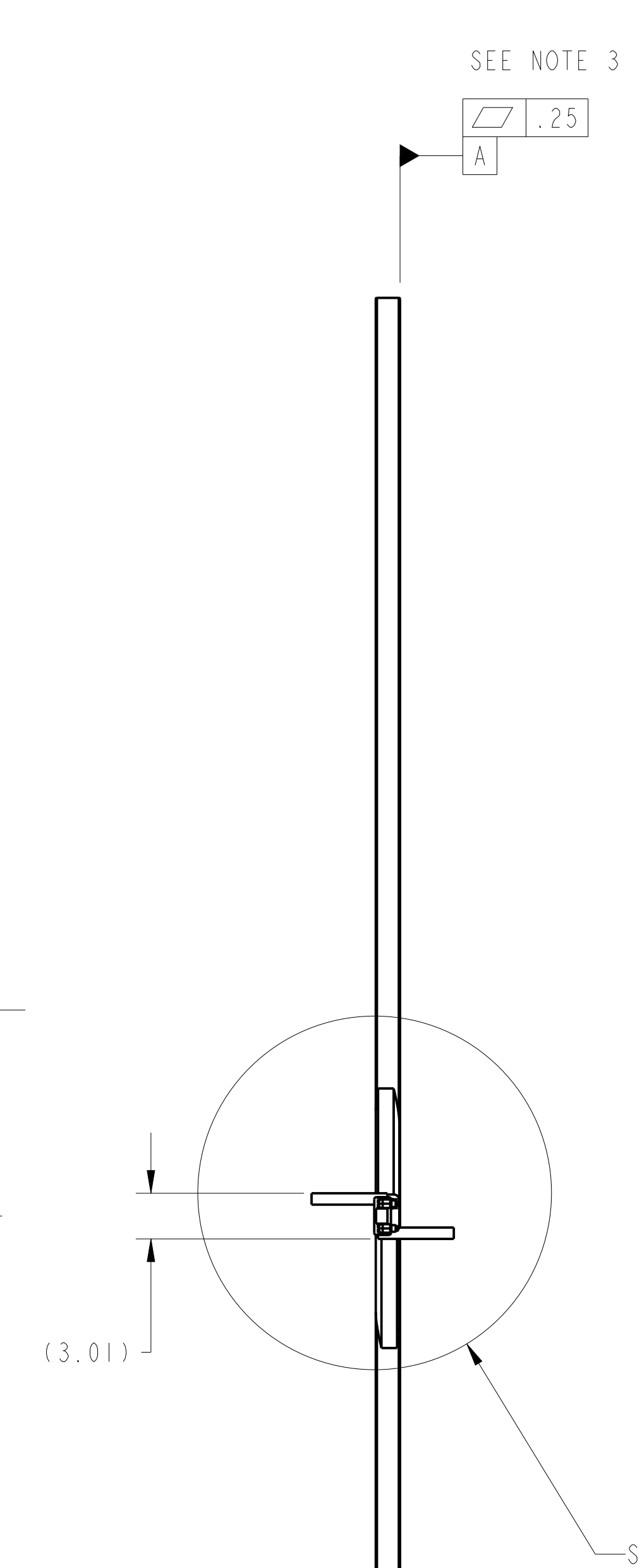
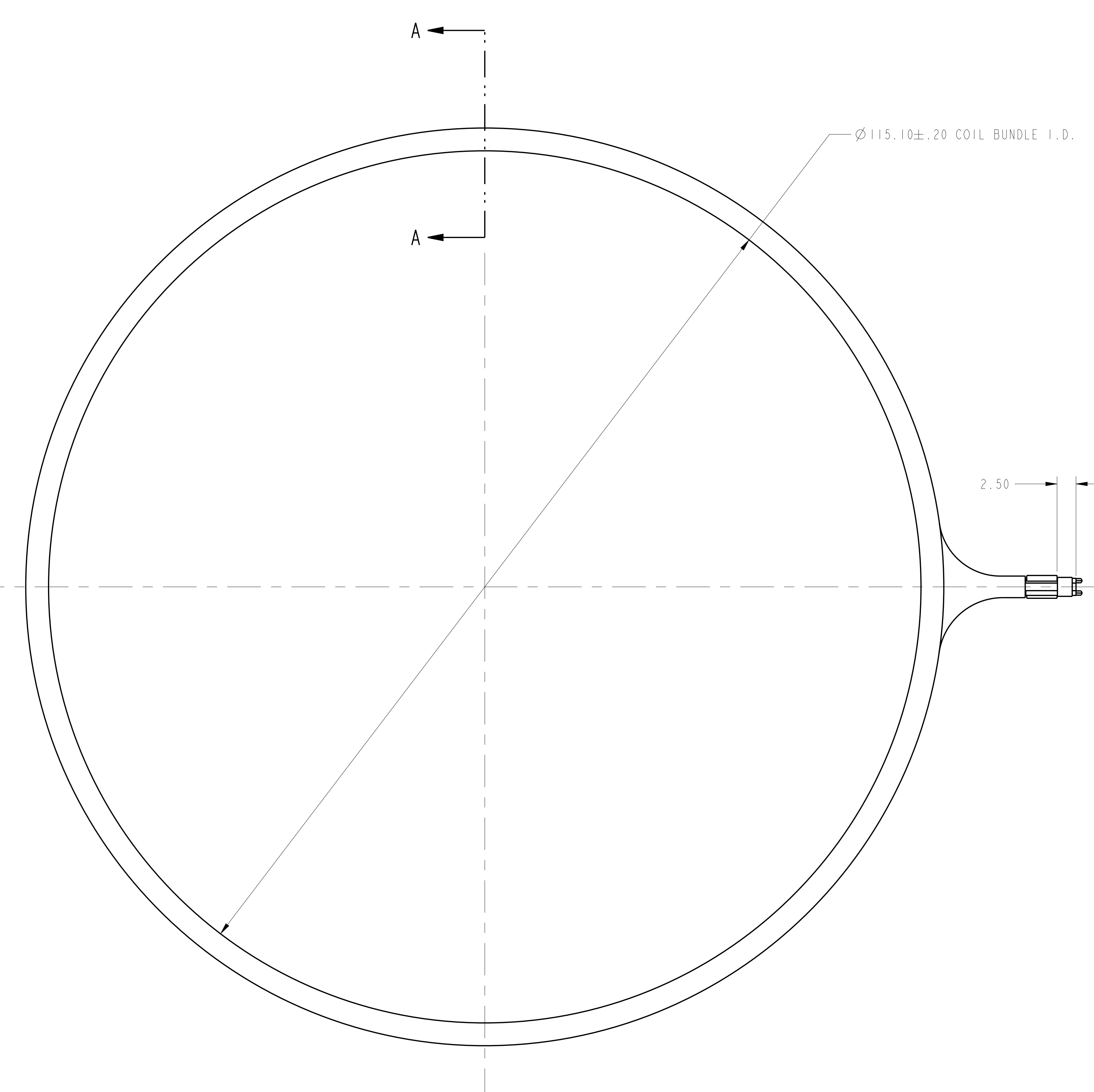
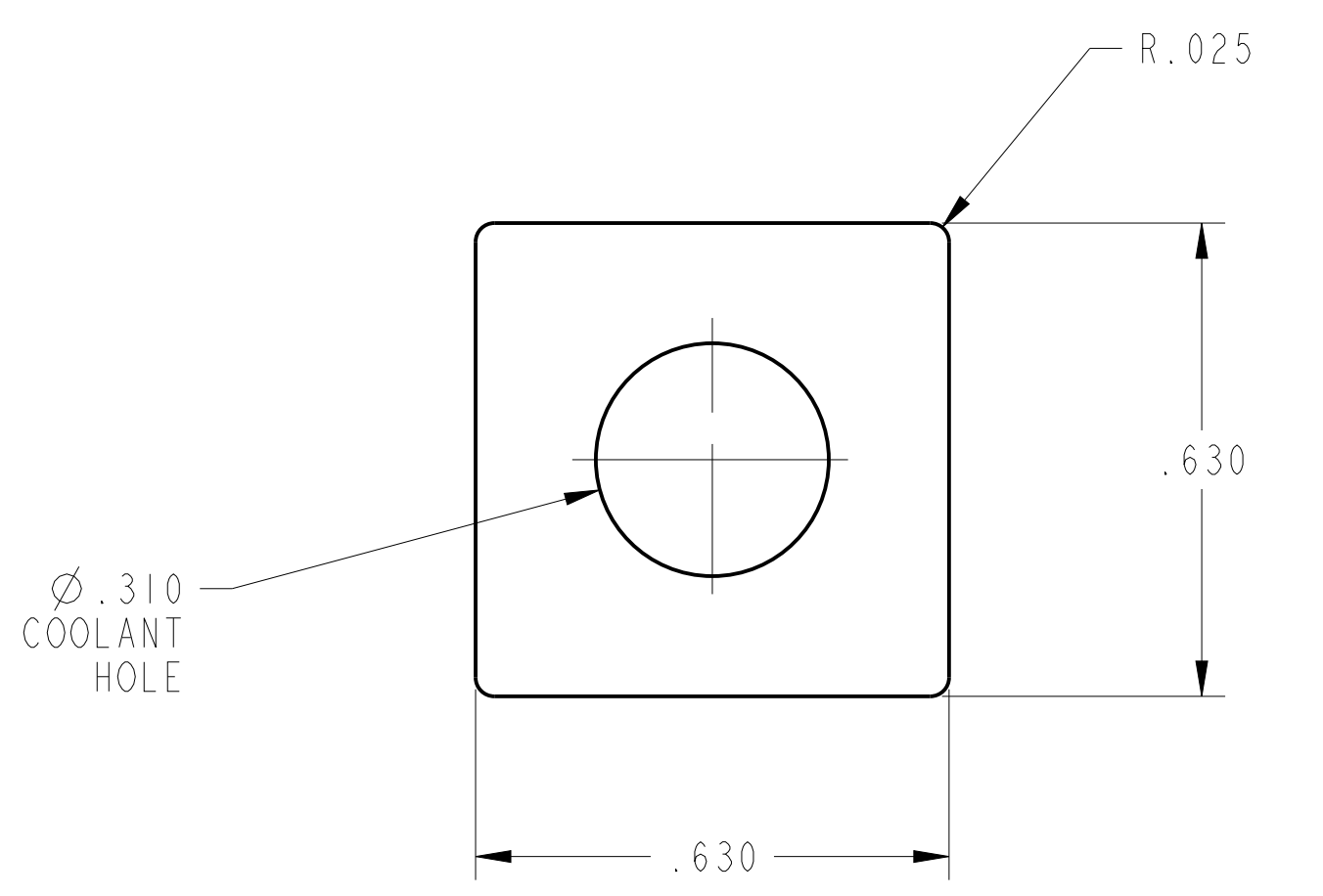

1 COIL CONDUCTOR

-01 ASSEMBLY EF COIL ASSEMBLY

NOTES

1. MANUFACTURE EF COIL TO SPECIFICATION FLARE-SPEC-01.
2. INSULATION IS SPECIFIED IN THE MANUFACTURING SPEC FLARE-SPEC-01.
3. FLATNESS APPLIES TO MEASUREMENTS TAKEN WITH COIL SUPPORTED AT SIX LOCATIONS EVENLY SPACED 60° APART.
4. FILLERS (ITEMS 3, 4, 5 & 9) ARE MANUFACTURED PER REQUIREMENTS SPECIFIED IN FLARE-SPEC-01.
5. APPLY GROUND WRAP AND TURN TO TURN INSULATION ON LEADS FROM BODY OF COIL LEADING UP TO FLAGS AND ON ENDS OF LEADS PAST FLAGS. SECURE LEADS TOGETHER BY OVERWRAPPING BOTH LEADS WITH 4 HALF LAP LAYERS OF EGLASS PER FLARE-SPEC-01.
6. DRILL AND TAP END OF COIL CONDUCTOR FOR 1/8 NPT THREAD TO MOUNT TUBE FITTING.
7. WELDING AND BRAZING SHALL BE PERFORMED IN ACCORDANCE WITH THE REQUIREMENTS OF PPPL PROCEDURE ENG-037 AND ASME SECTION IX. VISUAL WELD INSPECTION SHALL BE PERFORMED IN ACCORDANCE WITH THE INSPECTION CRITERIA OF ASME B31.9.

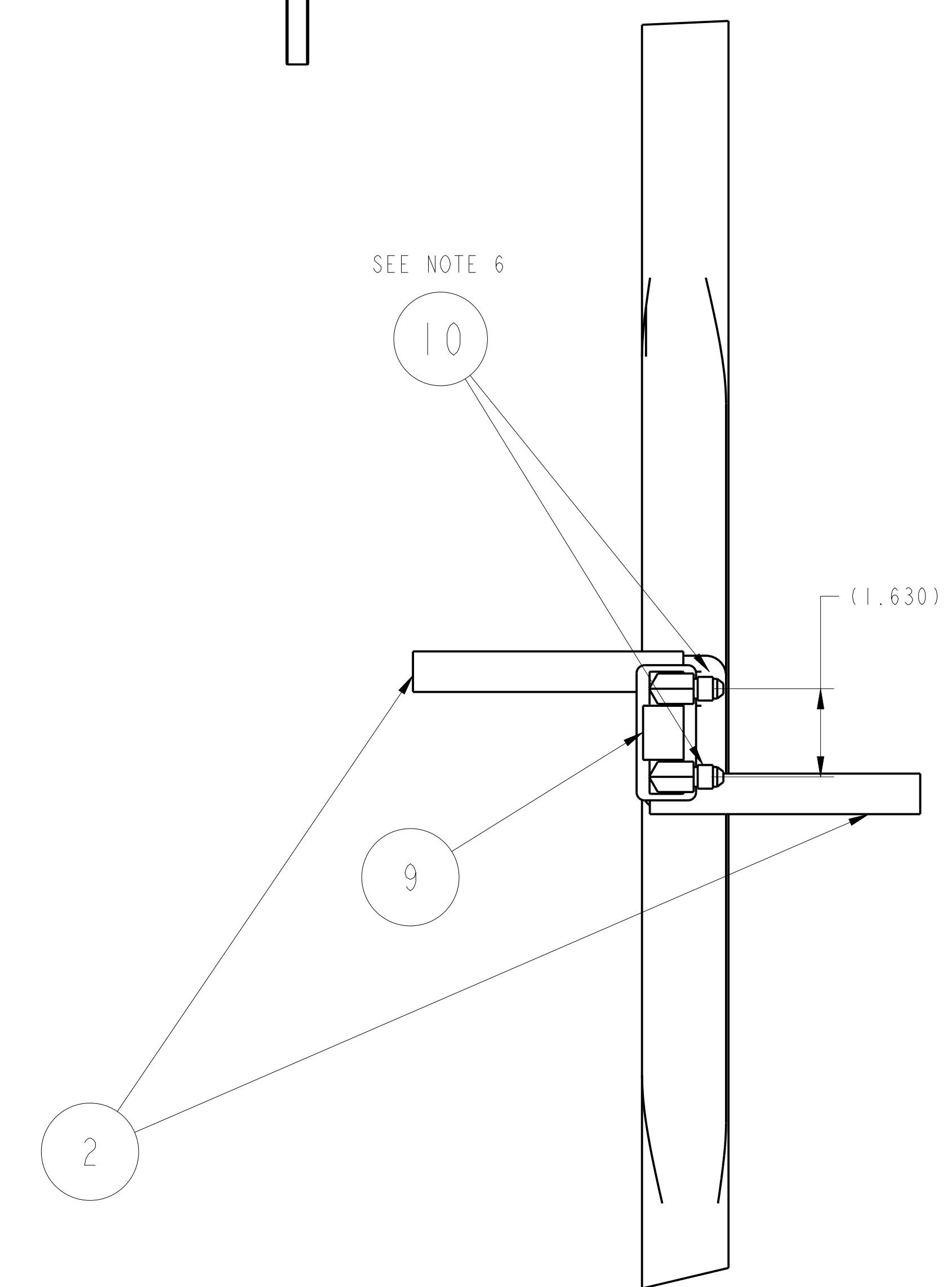

DETAIL B
SCALE 0.500

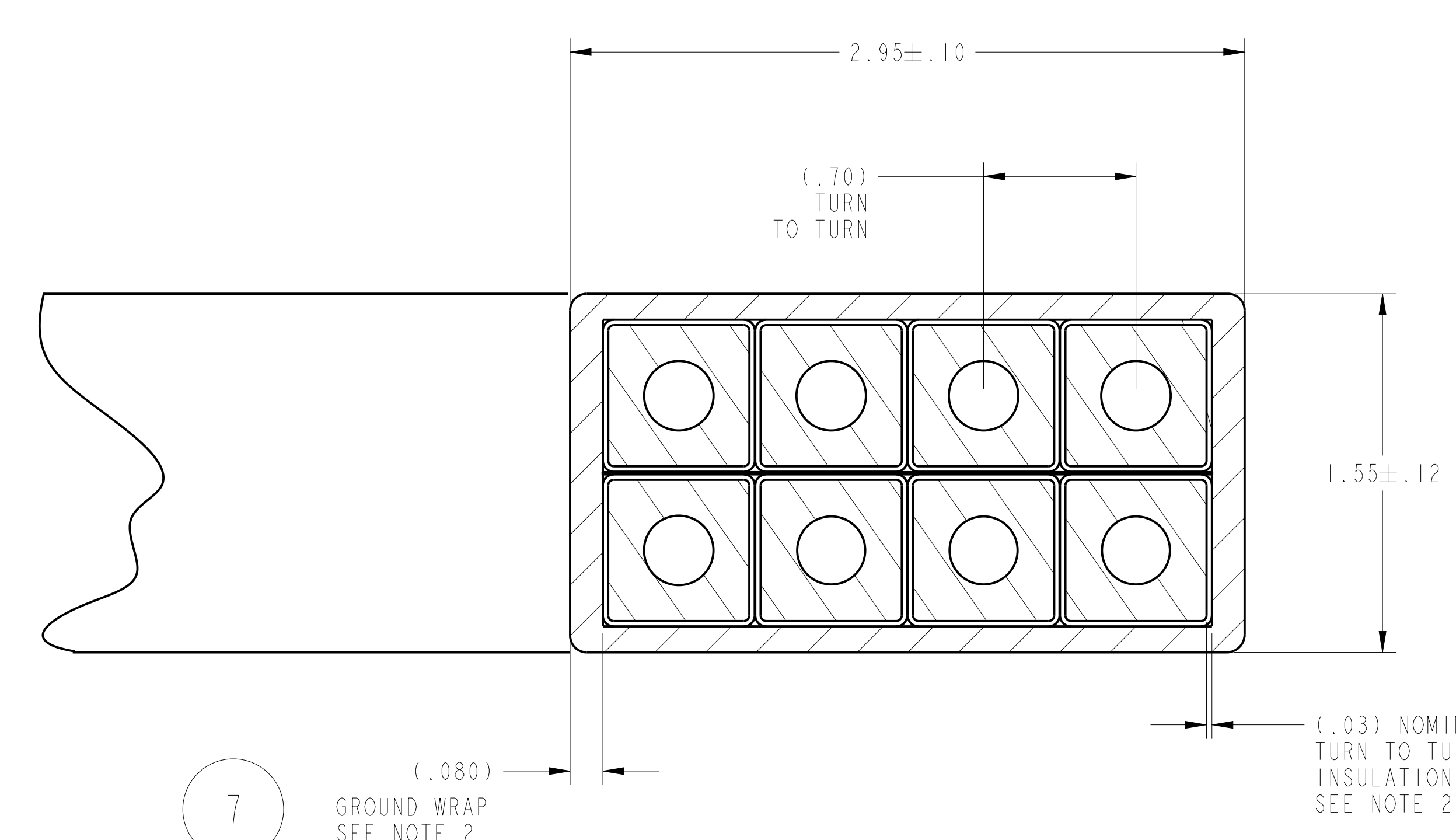

SECTION A-A
ROTATED
SCALE 2.000

QTY	PART NO	DRAWING NO	NOMENCLATURE OR DESCRIPTION	MAT'L	QTY REQD
2	10	COMM	TUBE FITTING, PARKER 4 CTX-B OR EOUIV	BRASS	
1	9	E-FL100-001-9	FILLER - TYPE D	G-10	
1	8	E-FL100-001-8	INSULATION, TURN TO TURN	SEE NOTE 2	
1	7	E-FL100-001-7	GROUND WRAP	SEE NOTE 2	
1	6	E-FL100-001-6	GLASS BARRIER	KAPTON/GLASS	
1	5	E-FL100-001-5	FILLER - TYPE A	G-10	
1	4	E-FL100-001-4	FILLER - TYPE B	G-10	
1	3	E-FL100-001-3	FILLER - TYPE C	G-10	
2	2	E-FL100-001-2	LEAD FLAG	COPPER	
1	1	E-FL100-001-1	COIL CONDUCTOR	COPPER	
1			THIS DRAWING	EF COIL ASSEMBLY	

PARTS LIST

GENERAL NOTES

1. PPPL APPROVED DRAWINGS TAKE PRECEDENCE OVER MODEL DIMENSIONS.
2. WHEN MODELS ARE PROVIDED, VENDOR MUST VERIFY THAT MODEL DIMENSIONS CONFORM WITH PPPL APPROVED DRAWINGS PRIOR TO FABRICATION.

MAGNETIC PERMEABILITY REQUIREMENT (SEE NOTES)	
YES	NO
<input type="checkbox"/>	<input checked="" type="checkbox"/>

RELEASE LEVEL: Fabrication
DWG VERSION NO: 0.4

RELEASED FOR FABRICATION / INSTALLATION
PPPL Drafting

WELDING ENGINEER
APPROVED: _____ DATE: _____

COMPUTER GENERATED DRAWING MANUAL CHANGES NOT PERMITTED Pro E	CENTRAL FILES: UNLESS OTHERWISE SPECIFIED DIMENSIONS ARE IN INCHES MACHINE SURFACES BREAK SHARP EDGES .055/.020	PRINCETON PLASMA PHYSICS LABORATORY FACILITY FOR LABORATORY RECONNECTION EXPERIMENT COIL SYSTEMS POLOIDAL FIELD COIL EF COIL ASSEMBLY
DO NOT VERIFY INFORMATION BY SCALING DRAWING SCALE: .125	TOLERANCES - NON-CUMULATIVE DECIMAL - INCH FRACTIONS ± .000 0" - 12" ± .000 ± .030 12" - 24" ± .010 ± .010 24" - 48" ± .010 ANGULAR ± .05 15° - 90° ± .02 90° - 120° ± .02	DIV: MECH. ENG. DATE: 1/28/2015 ENG: M KALISH DSN: J MITCHELL CHK: M KALISH
NEXT ASSEMBLY		APPROVED: _____ E-FL100-001
		SHEET 1 OF 3 REV 0

NO.	REVISION	BY	CH	SUP	APPROVED	DATE

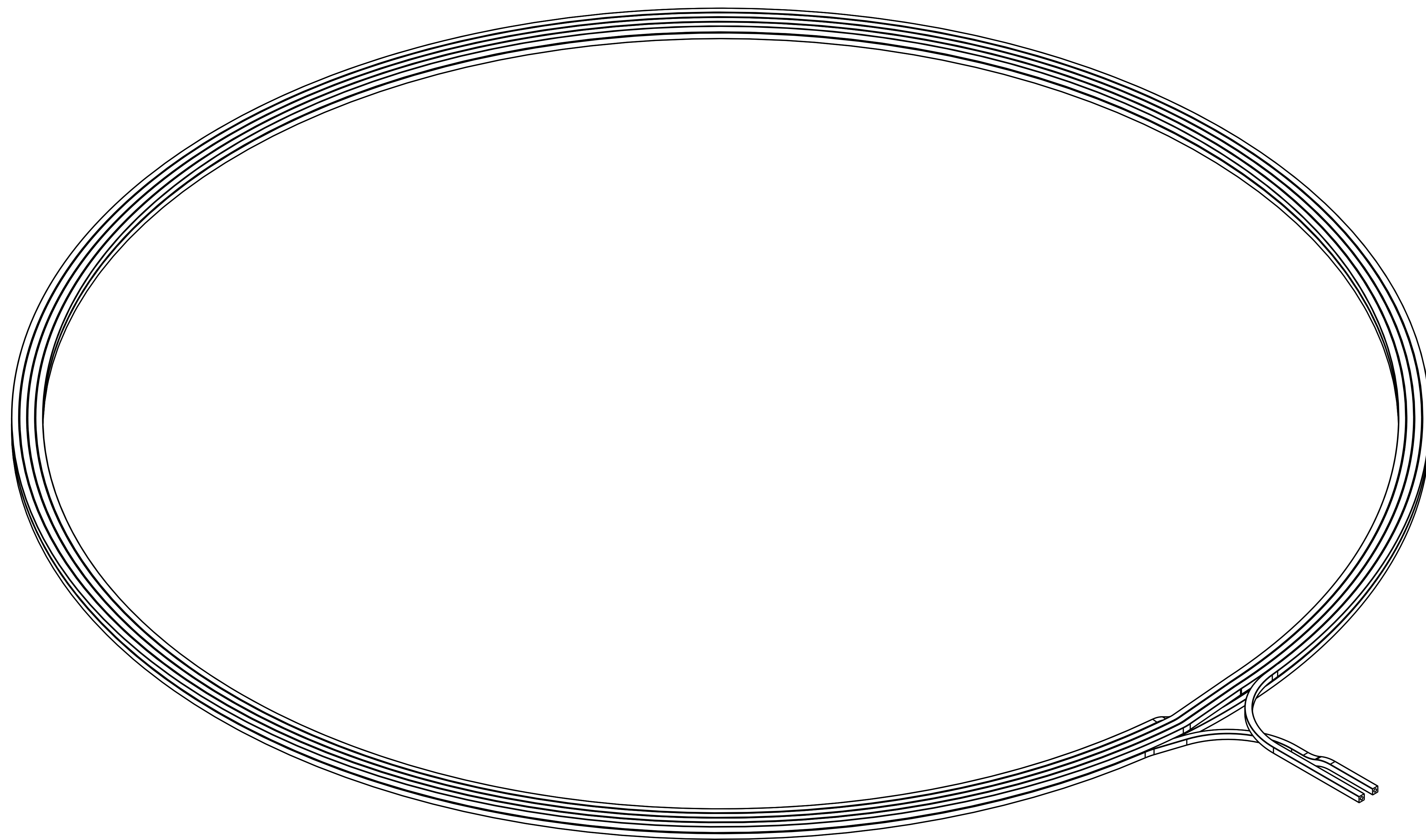

COIL BUNDLE REFERENCE ISOMETRIC
(FILLER PIECES AND GROUND WRAP NOT SHOWN)

SCALE 0.200



NOTE:
THIS SYMBOL INDICATES
WINDING DIRECTION
OF LAYERS

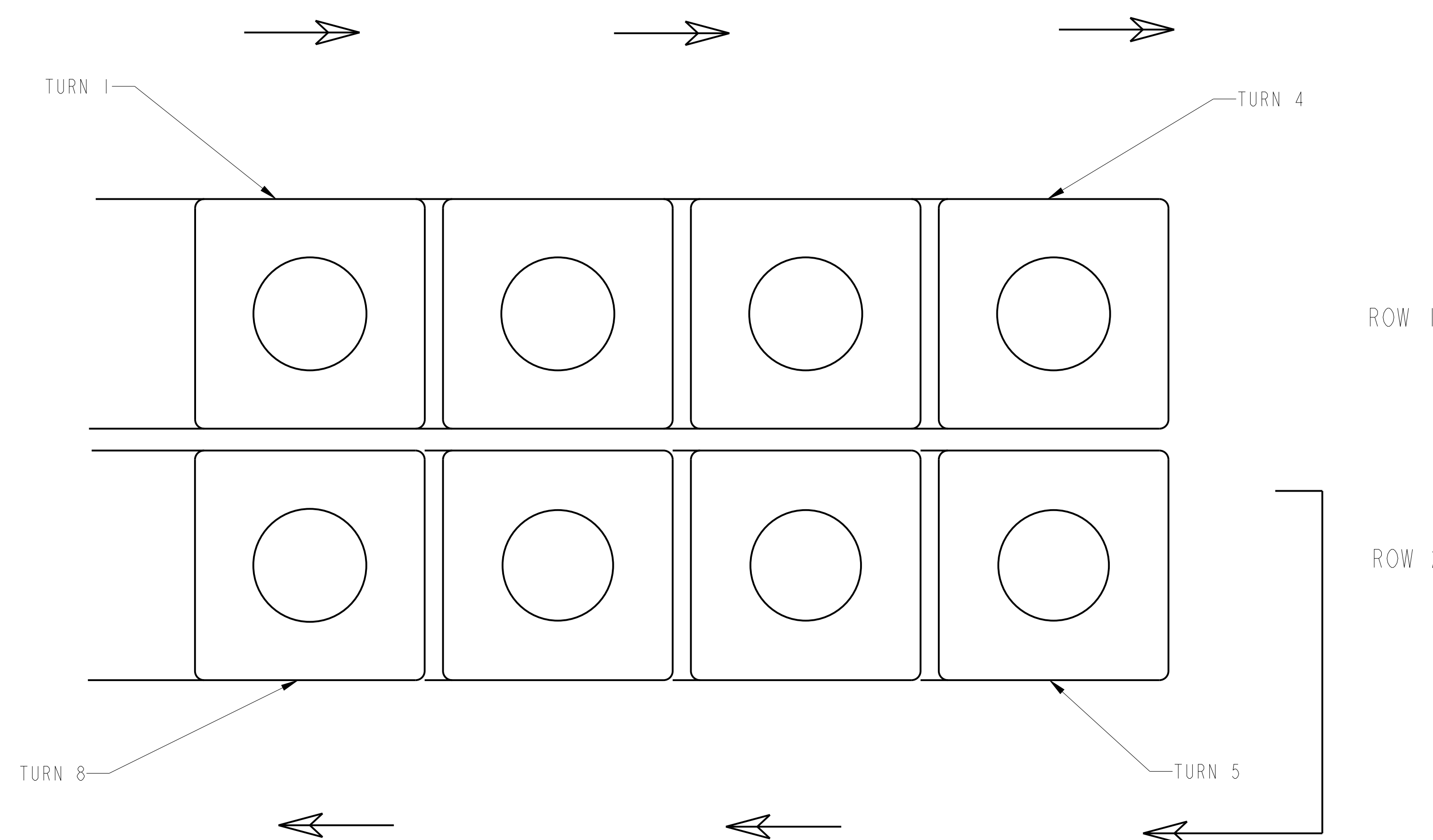

WINDING SCHEME

SEE SHEET 1 FOR NOTES & PARTS LIST

GENERAL NOTES

1. PPPL APPROVED DRAWINGS TAKE PRECEDENCE OVER MODEL DIMENSIONS.
2. WHEN MODELS ARE PROVIDED, VENDOR MUST VERIFY THAT MODEL DIMENSIONS CONFORM WITH PPPL APPROVED DRAWINGS PRIOR TO FABRICATION.

MAGNETIC PERMEABILITY
REQUIREMENT (SEE NOTES)

YES NO

RELEASED FOR
FABRICATION / INSTALLATION
PPPL Drafting

RELEASE LEVEL: Fabrication
DWG VERSION NO: 0.4

WELDING ENGINEER
APPROVED DATE

COMPUTER GENERATED DRAWING MANUAL CHANGES NOT PERMITTED Pro E	CENTRAL FILES: UNLESS OTHERWISE SPECIFIED	PRINCETON PLASMA PHYSICS LABORATORY FACILITY FOR LABORATORY RECONNECTION EXPERIMENT	
DO NOT VERIFY INFORMATION BY SCALING DRAWING	DIMENSIONS ARE IN INCHES MACHINE SURFACES BREAK SHARP EDGES .005/ .020	COIL SYSTEMS POLOIDAL FIELD COIL EF COIL ASSEMBLY	
SCALE:	TOLERANCES NON-CUMULATIVE	DIV: MECH. ENG. DATE: 1/28/2015	APPROVED
NEXT ASSEMBLY	DECIMAL-INCH FRACTIONS	ENG: M KALISH	M KALISH
	XXX 0.010 72°-120° 0.154	DSN: J MITCHELL	M KALISH
	ANGLER 20°-15 0.000-1.00° 0.102	CHK: M KALISH	CHK SUPV
			E-FL100-001
			SHEET 2 OF 3 REV 0

NO.	REVISION	BY	CH	SUP	APPROVED	DATE

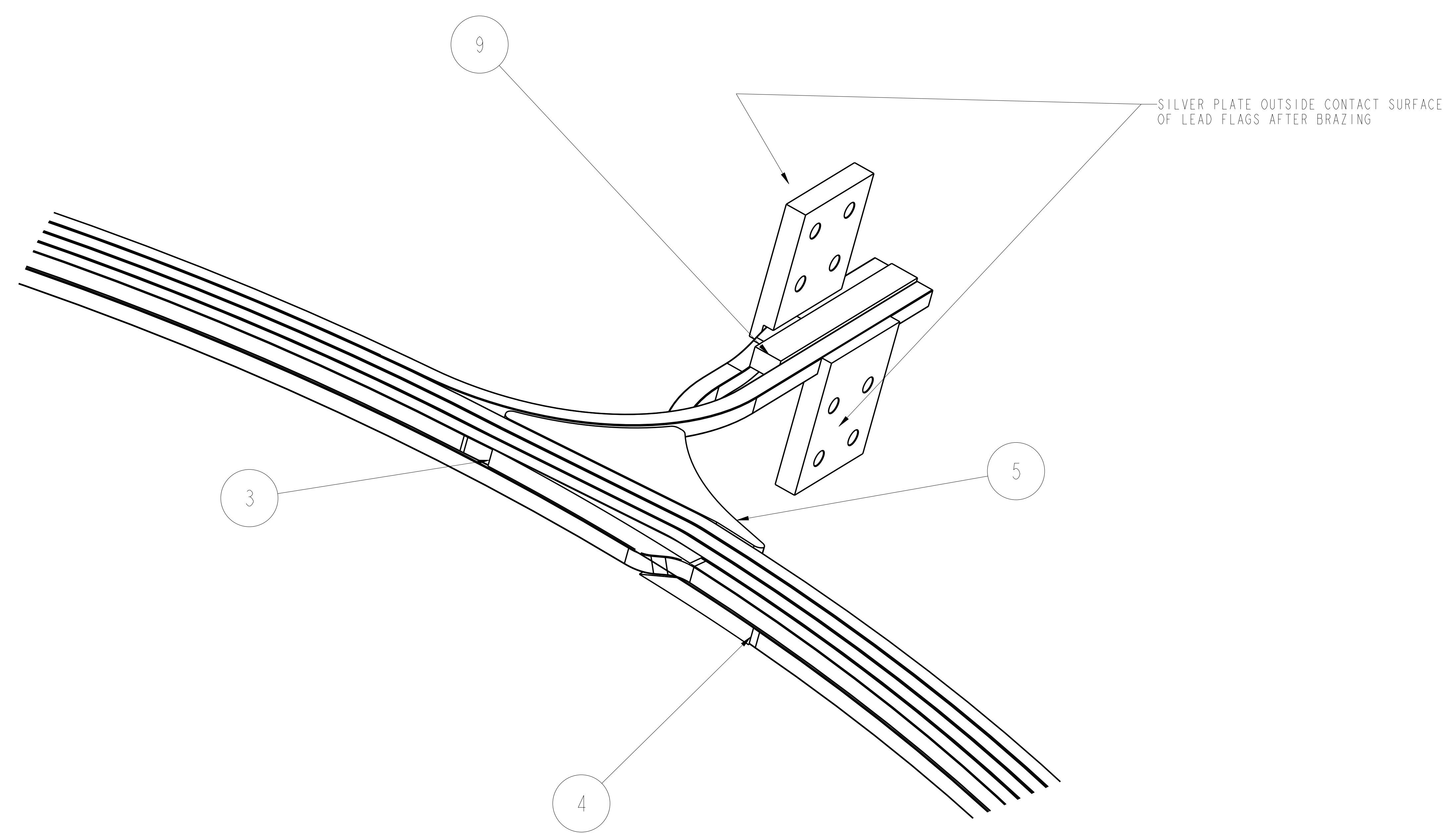

GROUND WRAP REMOVED IN VIEW FOR CLARITY
SCALE 0.500

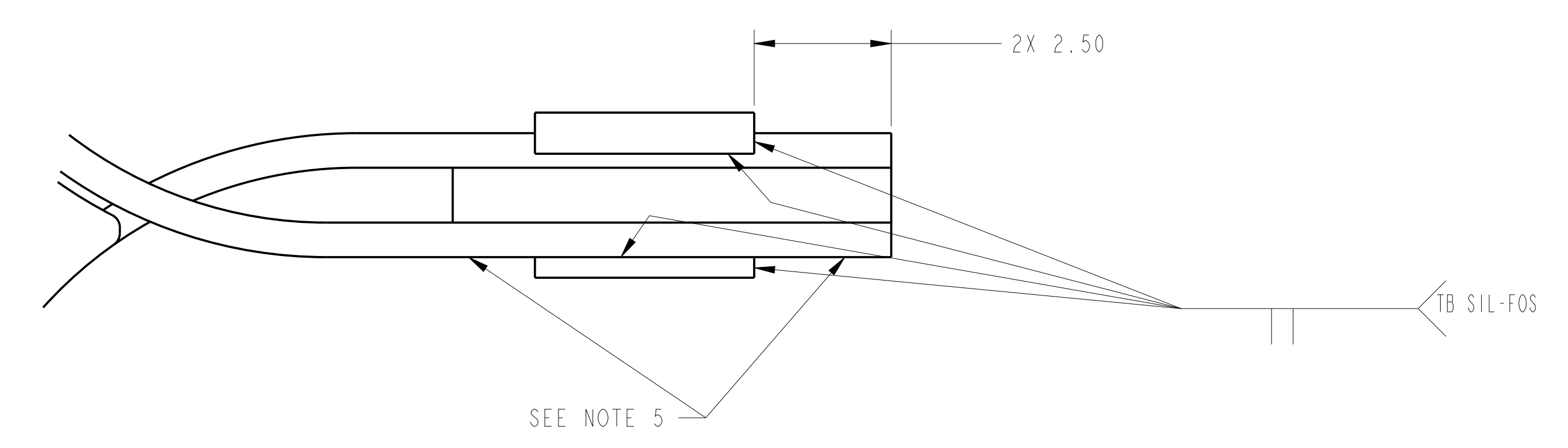
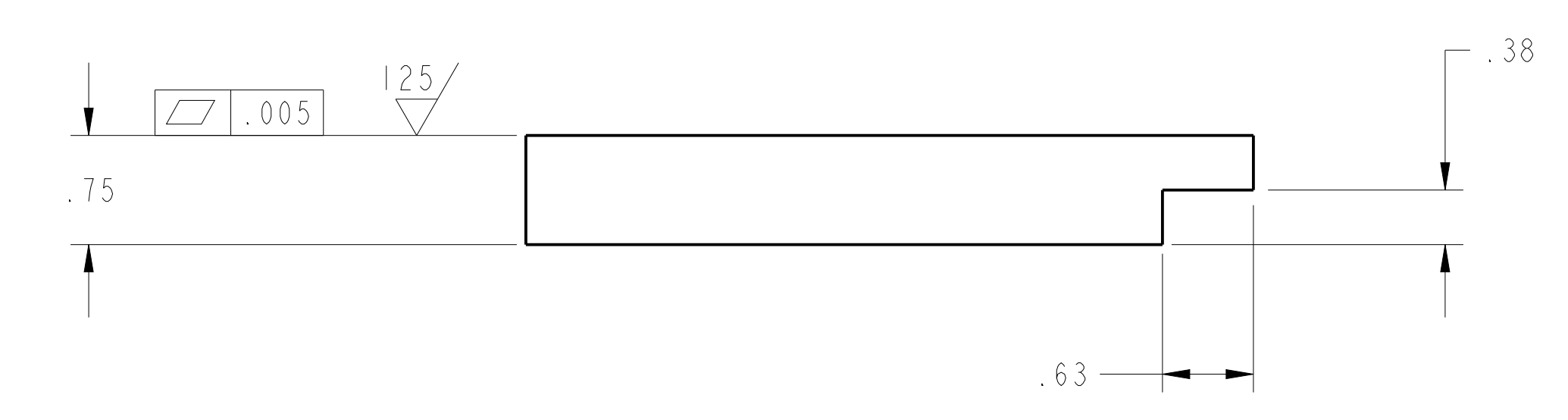

BRAZING DETAIL
SCALE 0.500

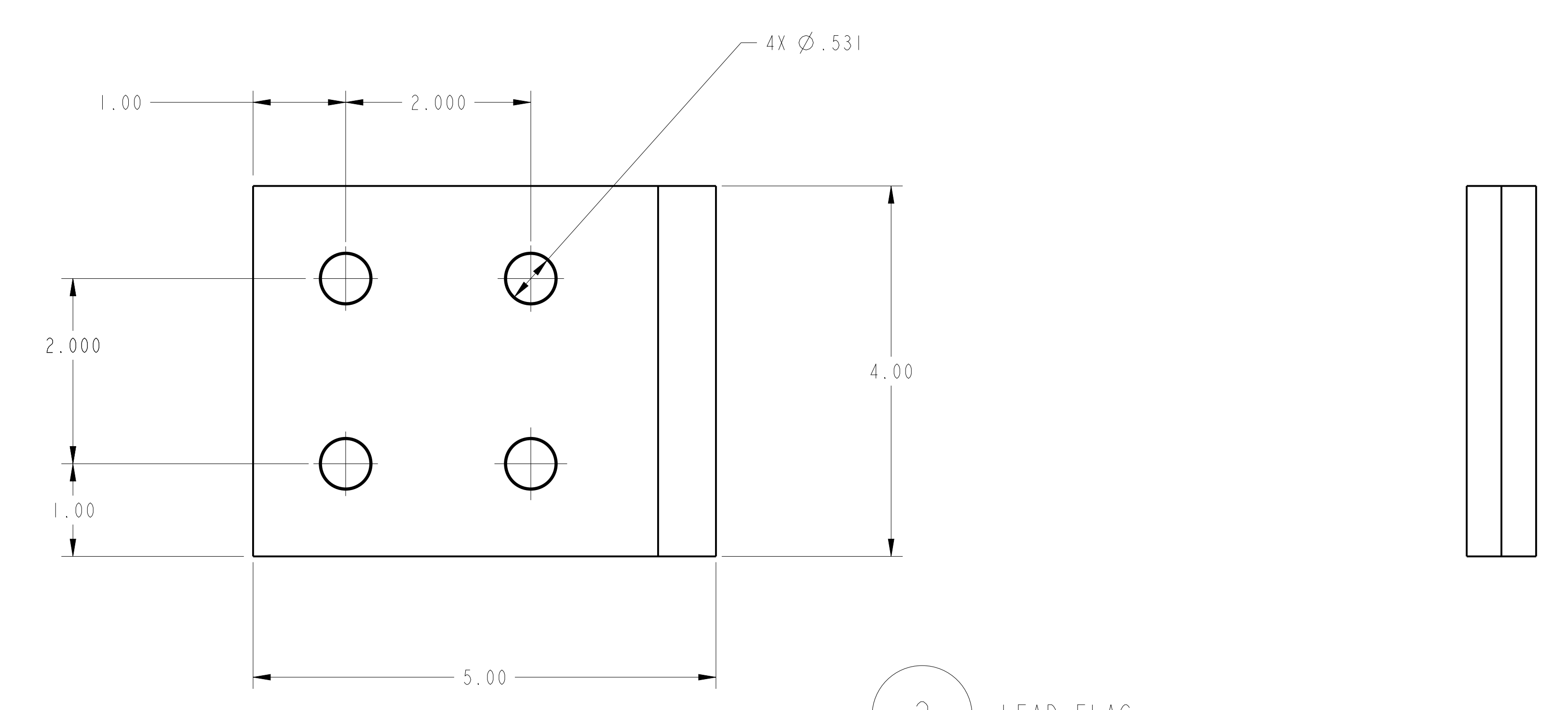

2 LEAD FLAG

SEE SHEET 1 FOR NOTES & PARTS LIST

GENERAL NOTES
1. PPPL APPROVED DRAWINGS TAKE PRECEDENCE OVER MODEL DIMENSIONS.
2. WHEN MODELS ARE PROVIDED, VENDOR MUST VERIFY THAT MODEL DIMENSIONS CONFORM WITH PPPL APPROVED DRAWINGS PRIOR TO FABRICATION.

MAGNETIC PERMEABILITY REQUIREMENT (SEE NOTES)	
YES	NO

RELEASED FOR FABRICATION / INSTALLATION
PPPL Drafting

RELEASE LEVEL: Fabrication
DWG VERSION NO: 0.4

WELDING ENGINEER
APPVD: M. Stryer DATE: 12/10/2015

COMPUTER GENERATED DRAWING MANUAL CHANGES NOT PERMITTED Pro E	CENTRAL FILES: UNLESS OTHERWISE SPECIFIED	PRINCETON PLASMA PHYSICS LABORATORY PRINCETON UNIVERSITY FACILITY FOR LABORATORY RECONNECTION EXPERIMENT	
DO NOT VERIFY INFORMATION BY SCALING DRAWING	BREAK SHARP EDGES .055/.020	COIL SYSTEMS POLOIDAL FIELD COIL EF COIL ASSEMBLY	
SCALE:	TOLERANCES NON-CUMULATIVE	DIV: MECH. ENG.	DATE: 1/28/2015
NEXT ASSEMBLY	DECIMAL-INCH FRACTIONS	ENG: M KALISH	APPROVED
	XXX 0.030 12°-12° 0.174	DSN: J MITCHELL	M KALISH
	ANGULAR 0.0°-15° 0.000 120° 0.172	CHK: M KALISH	CRK SUPV
		EM	
			E-FL100-001
			SHEET 3 OF 3 REV 0