

Specification for the Poloidal Field Bank Modules
Capacitor Charge/Discharge Power Supply (CCDPS) for FLARE

March 11, 2016

Contents

1 Specifications for Poloidal Field (PF-A and B) bank modules	4
1.1 Description	4
1.2 Full Assembly: module	6
1.3 Capacitors	7
1.4 Forward Switch	7
1.5 Crowbar Switch	7
1.6 Buswork	8
1.7 Charging	9
1.8 Dump	9
1.9 Harnessing	9
1.10 Polarity switching	10
1.11 Diagnostics	10
1.12 Safety	10
1.13 Cooling requirements	10
1.14 Connections	11
1.15 Environmental requirements	12
2 References	13
3 Appendices	13
3.1 Engineering Drawings and Vendor Specifications	13

List of Tables

1	Target parameters for PF bank	4
2	Bus Clamp Dimensions by Bank (inches)	13

List of Figures

1	Poloidal Field Circuit Schematic	4
2	PSpice Poloidal Field Schematic and Analysis	5
3	Engineering design point for bank module	6
4	Capacitor detail	7
5	Switch detail - both forward and crowbar are shown.	8
6	Buswork detail.	8
7	Charging switch and connection detail.	9
8	Dump detail for the PF bank module.	10
9	Connections	11
10	Schematic for charge, dump and ground relay control.	12
11	PF Bleed Resistor Channel	13
12	Ignitron Cage - Copper	14
13	Ignitron Cage - Stainless	15
14	PF Bus Upper	16
15	PF Bus Lower	17
16	PF Bus Insulation	18
17	PF Bus Vertical Support - 2 Off	19
18	PF Bus Vertical	20
19	PF Bus Resistor	21
20	PF Bus Clamps	22
21	PF Cable Header	23
22	Dump Lid	24
23	Dump Stick Eyehook Bracket	25

1 Specifications for Poloidal Field (PF-A and B) bank modules

1.1 Description

Bank schematic is shown in Fig. 1. Starting on the left side of the figure, the module is charged by connecting both positive and negative supply lines. A power supply protection circuit is shown (although the components are distributed between the charge supply rack and the capacitor modules – please refer to the Charge Specification for details). A bleed resistor is connected in parallel with each capacitor and is used to slowly drain bank charge in case of failure of all other dumps (i.e. if left alone overnight the bank will passively discharge below the NFPA 70E safe approach threshold of 50 V). Before each shot, the dump load relays are opened. Then the charging relays are closed and the charging supply charges the caps. When the set-point is reached, the charging switches are opened. The capacitors are then discharged through the inductive and resistive load of the coil, and crowbarred with a delay corresponding to peak current. For PF, it is required to crowbar the circuit at values of peak current from 70% to -50%. Following a shot, the dump switch is closed to ensure the capacitors are fully discharged. After the bank has dumped, the ground switch is closed to connect cap terminals to ground. Capacitor fuses are thin wires designed to blow during an over-current event. They will be used on each cap and will connect the capacitor to the busbar. Each of the components will be described in the following sections.

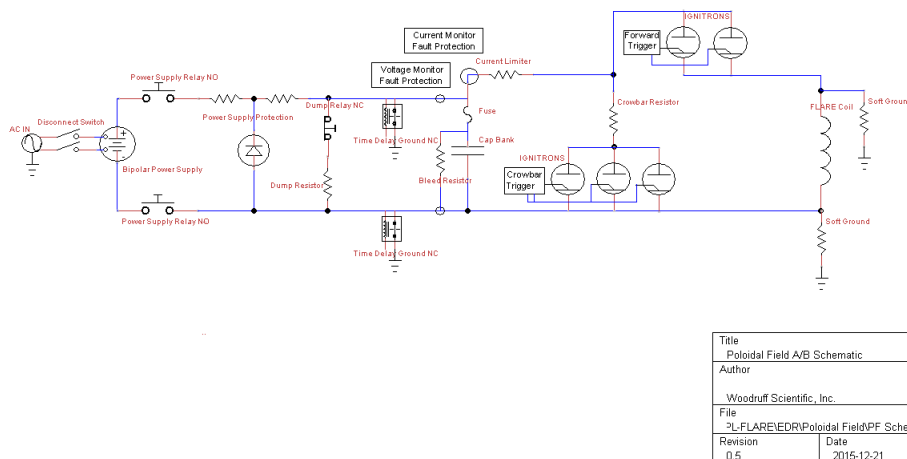
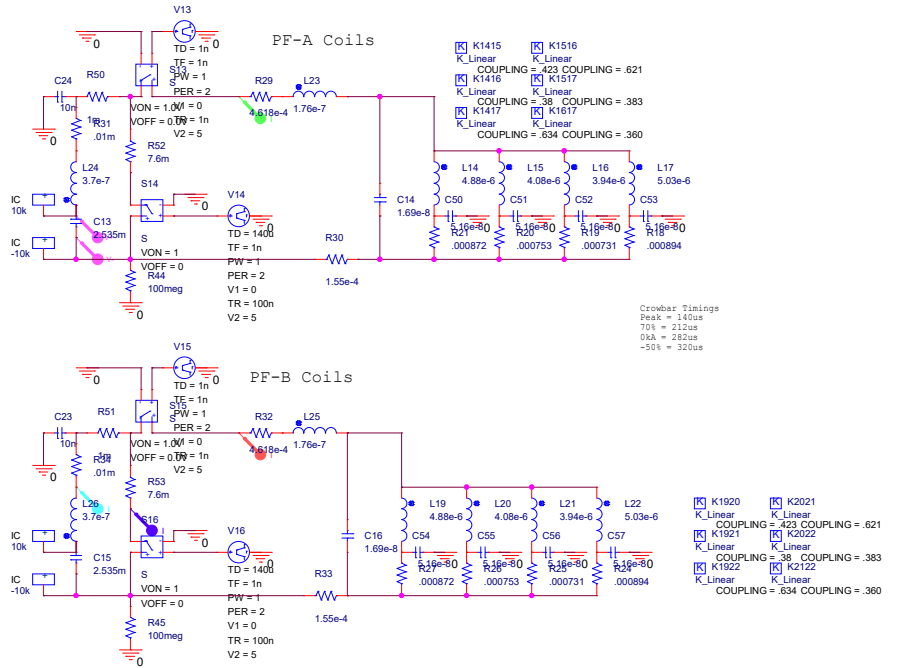

Figure 1: Poloidal Field Circuit Schematic

The PFbank module is designed to energize the PF coil set, providing a current pulse per Fig. 2, meeting the specifications in Table 1. The power supply system shall be designed for a minimum of 10 years design life and a minimum of 100,000 full power shots with regular maintenance.

	PF-A	PF-B
# Sub-Coils	4	4
V (Volts)	20000	20000
I _{max} (A)	540000	540000
Day 1	0	0
Peak I (kA)	540	540
trise (ms)	< 0.11	< 0.11
tcrowbar	Peak	Peak
Swing I _{min}	70%	70%
	-50%	-50%

Table 1: Target parameters for PF bank



** Profile: "SCHEMATIC1-trans1" [C:\Users\simon\Desktop\PF-A_B\pf_a_b-pspicefiles\schematic1\trans1.si...
 Date/Time run: 01/21/16 12:09:48 Temperature: 27.0

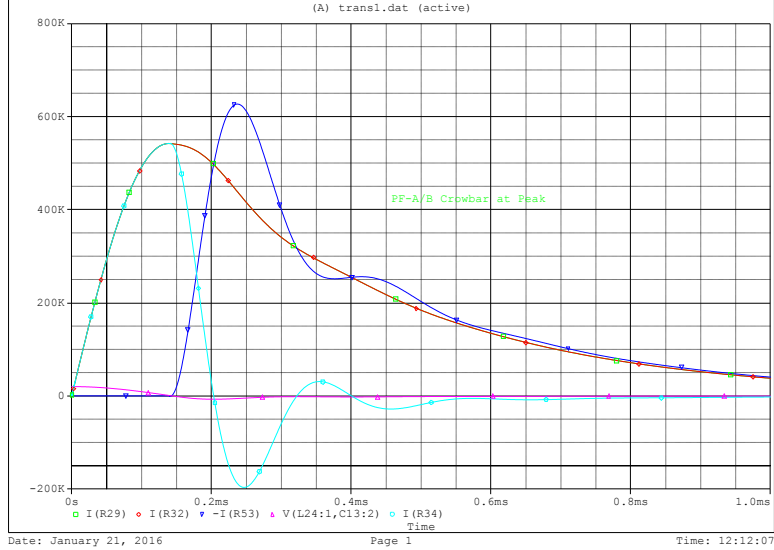

Figure 2: PSpice Poloidal Field Schematic and Analysis

1.2 Full Assembly: module

Fig. 5 shows the PF-A modules. PF-B is identical. The bank modules are mounted on two 48 inch square steel pallets.

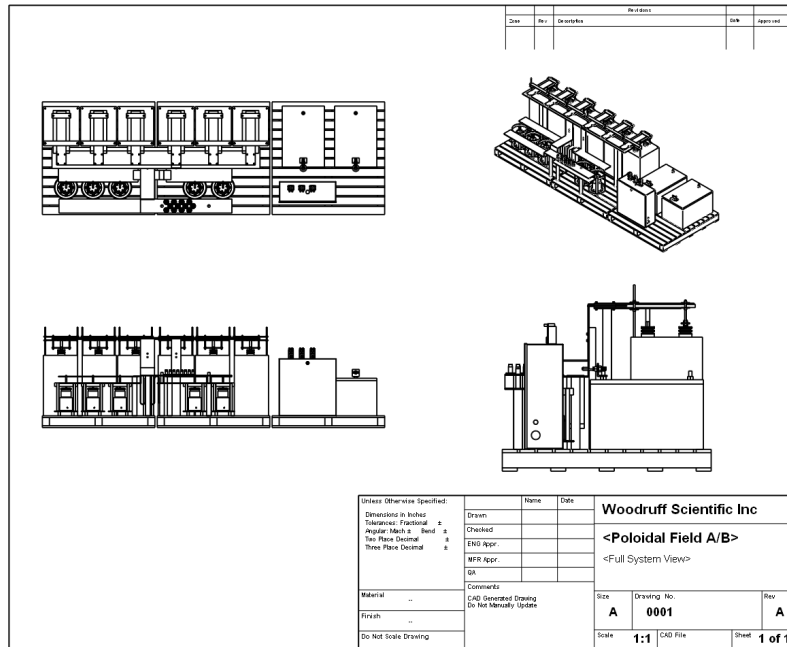
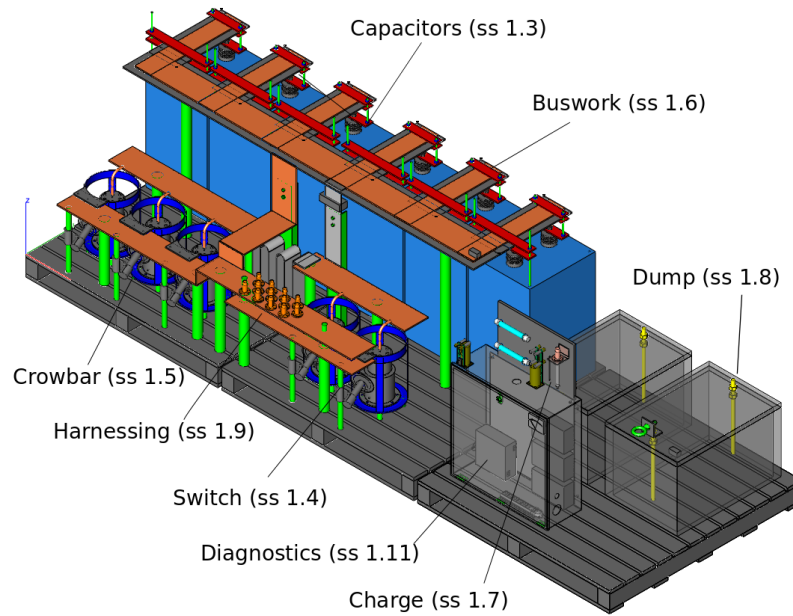

Figure 3: Engineering design point for bank module

The full assembly will have a footprint no smaller than 32sqft with a maximum of 160sqft for egress and maintenance (2 feet on each side), and will be engineered as 2 modules (on 2 pallets) that can be transported and installed onsite with only a small number of connections (connections for 110V power, high voltage and trigger lines (see more details below and connection table below)). The PF Bank and all related components will be mounted on 3 48"x48" standard pallets, total height under 50 inches, total weight per pallet of 1200lbs. Assembly instructions will be provided.

1.3 Capacitors

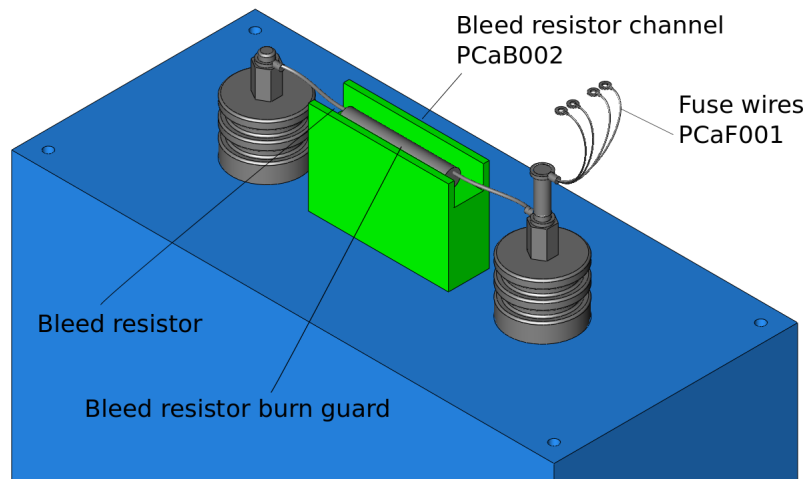

Figure 4: Capacitor detail

The capacitors are expected to see reversal voltages during the experimental shots. The voltage reversal on the caps will be specified to be 95%. Each capacitor unit should be individually fused and self-protected. Energy dumping resistor(s) shall be specified for safe dissipation of stored energy (see below). The dissipation time should be limited to the shorter of the relevant industrial standards or the experimental needs. The PF bank will use 6 NL440-20KV Capacitors, by Richardson Electronics. They have a rated capacitance of 440uF and a rated voltage of 20kVDC. They are rated for 95% discharge voltage reversal. The capacitors are expected to survive at least 500,000 full power shots without failure, per cap manufacturer specification see appendix for the Richardson specification. In parallel with each capacitor is a bleed resistor. These are a redundant dump mechanism for the stored energy. These resistors are sized to discharge the bank to below 50 volts over 12 hours. The bleed resistors are a passive “last resort” safing mechanism in case of failure of the water dump or loss of buswork connections, allowing the operator to leave the bank overnight to dissipate its stored energy. The bleed resistor shown in Fig. 4 is a 30kV 40W 60M Ω Ohmite MOX-H (see spec in appendix). Shown also in Fig. 4 are the fuse wires, which are 4 14AWG bare copper wires soldered into ring terminals. Burn guard will be mounted to the cap with double-sided adhesive tape (e.g. 3M Command Strips).

1.4 Forward Switch

Wherever practical and appropriate, PPPL prefers the following ignitron to be used. Ignitron model NL8900, by Richardson Electronics (see appendix). For the this bank, the forward switch will be such an ignitron. The ignitrons are expected to see reverse voltage and pulse currents. Life time of the ignitron contact shall not be significantly shortened or the minimum design life of the equipment should be maintained. The ignitrons are expected to survive a minimum of 10,000 full power shots without failure. The anode of the ignitron requires heating. This design will utilize a 500W infrared heater mounted close to the anode. The ignitron requires water cooling, provided by 1/4" NPT hose connected to a water chiller. Ignitrons are connected to the bus bar using 3 copper braids terminated with ring terminals and bolted with 1/4-20 bolts (see machining drawings for details).

1.5 Crowbar Switch

The crowbar switch on the PF bank utilize Ignitron model NL8900, by Richardson Electronics (see appendix). While two ignitrons are used in parallel in the forward direction, three are used in parallel in the crowbar due to the wide range of crowbar timings to be used. The ignitrons use the IG5F2-10 Ignitron Driver, also by Richardson Electronics. After the forward switch is fired, the crowbar will be fired after a delay corresponding

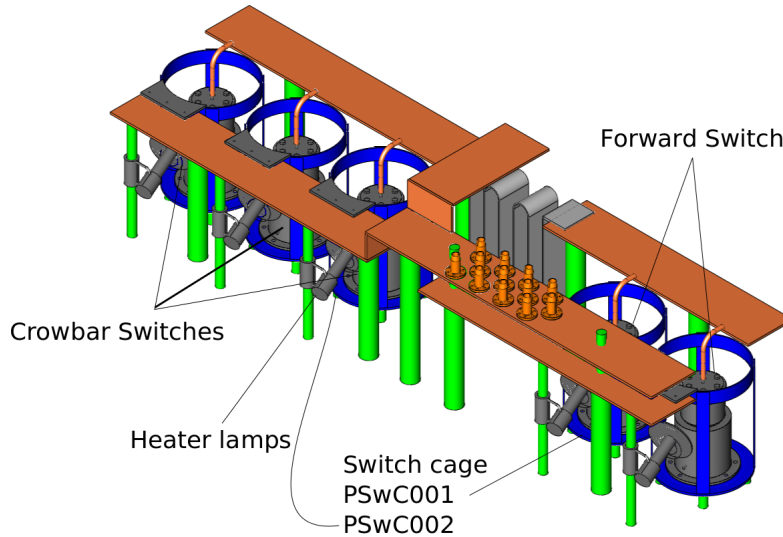

Figure 5: Switch detail - both forward and crowbar are shown.

to peak current and later. Ignitrons are connected to the bus bar using 3 copper braids terminated with ring terminals and bolted with 1/4-20 bolts (see machining drawings for details).

1.6 Buswork

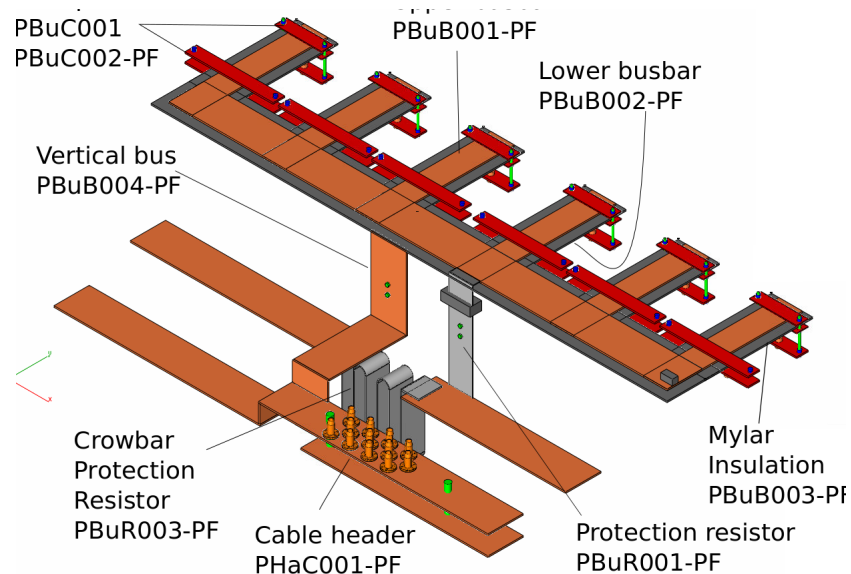

Figure 6: Buswork detail.

Buswork consists of busbars connected to the caps by use of brass adapters that are secured by 1/4-20 bolts and have knife-edges that will bite into the copper busbars (see detailed call-out in Fig. 6). A larger bus is used to interconnect all the smaller capacitor buses which then feeds into the current limiting stainless steel resistor. Outgoing and return busbars are isolated from each other by use of multiple layers of mylar sheet, with sufficient overhang to meet the 2E+1 stand-off requirement. A 1mOhm overcurrent protection resistor is provided in case of short failure, clamping the maximum current to tolerable thresholds for the

caps. The power supply should be properly insulated based on design. The rule of thumb to be followed is $2E+1$, where E is the maximum system voltage. All bus work should be taken into consideration so that the inductance does not limit the system performance.

1.7 Charging

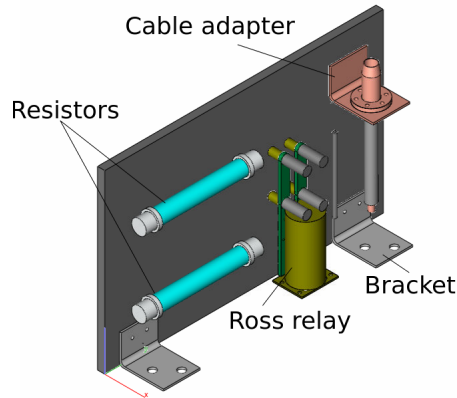

Figure 7: Charging switch and connection detail.

The charging supply will consist of two TDK-Lambda supplies, one 402L-10kV-POS-208VAC and one 402L-10kV-NEG-208VAC. The charge supplies are wired in series to create a ± 10 kV bipolar output. The two output lines each include a series resistor to improve regulation and limit output current under fault conditions. The lines are then split to run a cable to each capacitor module. At the capacitor module, the charge cable is connected across a diode that protects the charge supply in the event of a bank pre-fire (when the charge supply is connected to the bank). The diode prevents any bank reversal during pre-fire from imposing a reverse voltage at the charge supply. After the diode is a resistor that limits the charge current for the bank (and limits the protection diode current under reversal). The final connection to the capacitor busswork is made via a normally-open DPST Ross relay (E40-2PNO) which is only connected for charging, and is disconnected immediately prior to programmed discharge. Please refer to the separate specification for the charging supplies (treated as a separate sub-assembly). Charging cable is terminated at the bank with a custom connector, see Fig. 7.

1.8 Dump

Each capacitor module includes a resistor sized to dissipate the full-charge energy of the bank. The resistor material is an aqueous solution of copper sulfate with brass electrodes in a polycarbonate reservoir. The electrolyte concentration is tuned to discharge the bank to below 50 volts (the NFPA 70E safety threshold) within 30 seconds. This dump rate was chosen based upon a conservative estimate of the time required from removal of the Kirk key at the operator station to entry of the bank enclosure. The dump sizing is also designed to allow several sequential full-energy dumps at 3 minute intervals, but in this operation mode the resistor temperature shall be monitored remotely by the operator to ensure the temperature does not exceed 60°C (as per ASTM C1055) and that the water level is maintained. The normally-closed dump relay on each module (Ross E40-NC) will be energized only during charge, and will be de-energized to engage the dump upon removal of the Kirk key or at any emergency stop or interlock break. A temperature sensor is located on the outside lower section of each dump.

1.9 Harnessing

The harnessing sub-assembly comprises all of the interconnecting power cables from the CCDPS to the FLARE machine. The cabling will be triax of suitable current rating (see e.g. Dielectric Sciences specification

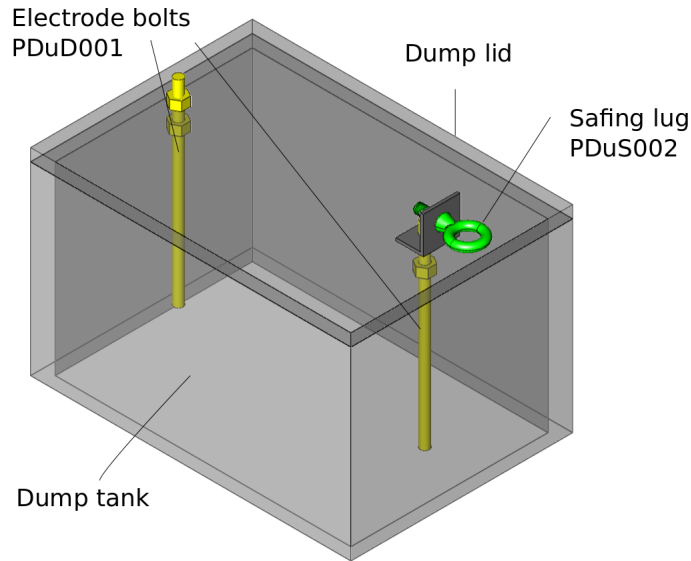

Figure 8: Dump detail for the PF bank module.

in the Appendix). 12 cables will connect to the cable header located close to the switches and between the dumps. Cable trays will be used to route cables from the capacitor banks to the device.

1.10 Polarity switching

No polarity switch is required for this module.

1.11 Diagnostics

Diagnostics must be provided to measure the forward current in the bus leading to the forward switch (see gray block on safety resistor in Fig. 6 for placement), the voltage of the bank module using a voltage divider, and the temperature of the over-current protection resistor, the temperature in the dump resistor and the temperature at the anode of the ignitrons. Each of these diagnostic measurements must be transmitted along a fiber-optic connection to the DAQ. Please see separate DAQ specifications for further information.

1.12 Safety

Monitoring (analog and digital voltage monitoring) will be required. A voltage divider at the bank will be used to monitor the charging voltage on the control computer (see specification for DAQ), and provide a signal for a panel-mounted analog indicator at the entry to the enclosure.

The PF bank module will be housed in a bay that separated it from other bank modules. Each side of the bank module may be separated by a 1/4 inch steel blast shield. The enclosure will be interlocked and procedures will be present to disable the bank before personnel access.

1.13 Cooling requirements

Ignitron switches in the PF module require a connection to a water coolant supply to provide a minimum of 10 degrees of relative temperature difference between anode and cathode. Water coolant is provided by connection of 1/4" NPT fittings on the base of the ignitron to a water chiller. See detailed specifications in the appendix.

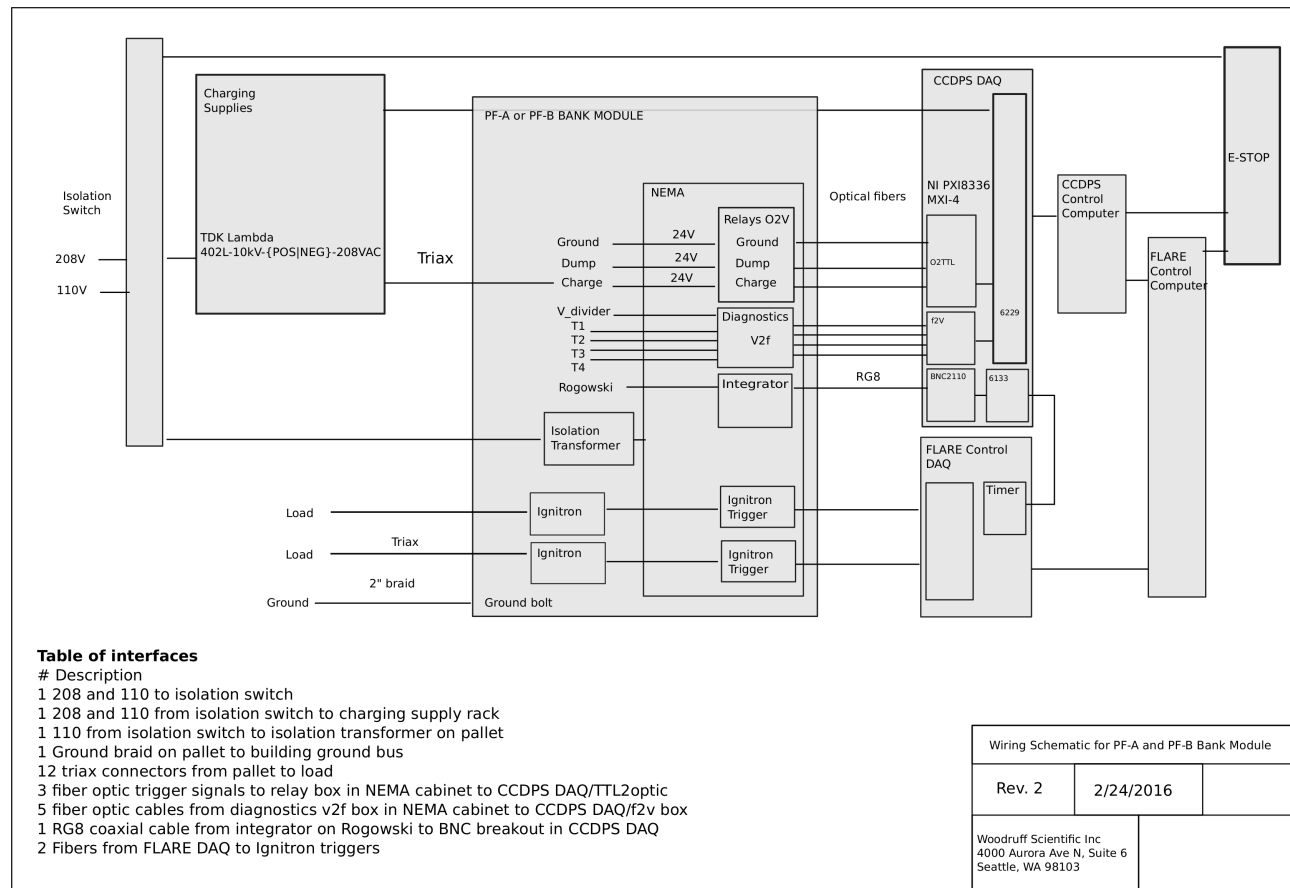

Figure 9: Connections

1.14 Connections

The connection schematic shows all of the connections that need to be made to the bank modules, power and control systems. From the left of Fig. 9, 208 and 110 power is fed to the bank enclosures via a Kirk key controlled isolation switch. This same switch can be energized by an Emergency Stop (E-stop) button located in the control room (this E-stop is digitized by both the FLARE control DAQ and the CCDPS control DAQ). If energized, the switch will drop all power to the enclosure, thereby killing power to the HV dump (normally closed) and charge (normally open) relays, and dumping bank energy into the cap dumps. The 110 and 208 power is delivered to the charging supply rack (located on it's own separate pallet), and 110 is also delivered to an isolation transformer mounted on the bank module pallet. Connections to the load are made by multiple triax cables (described above). Water is connected to the ignitron switches along 1/4" tubes from a shared chiller unit. The charge, dump ground relays are controlled by individual fiber-optic-enabled switches, with pulse signals sent from the CCDPS DAQ rack (Schematic shown in Fig. 10). Temperature sensor data are transmitted by fiber-optics from the pallet to the DAQ after conversion of voltage to frequency, then reconverting at the DAQ. A BNC connection is made from the current sensor integrator to the DAQ fast data acquisition (sampling at at least 1MHz). Timing synchronization is provided by the FLARE control DAQ. Switch firing is controlled here by the FLARE control computer and DAQ, by transmission of fire signal by fiber-optic connection. CCDPS DAQ requires 110V as input. CCDPS control computer requires 110V as input.

- Electrical input requirements: 208V three phase, 110V, less than 50 Amps (total for all banks at full charge is 100A)
- Load requirements: as specified in [1]

- Cooling requirements: chiller for ignitrons (see specification attached)
- Environmental requirements: dust free, see below
- Control signals needed as inputs: ESTOP and triggers (see Fig. 9)
- Control signals as outputs: none.

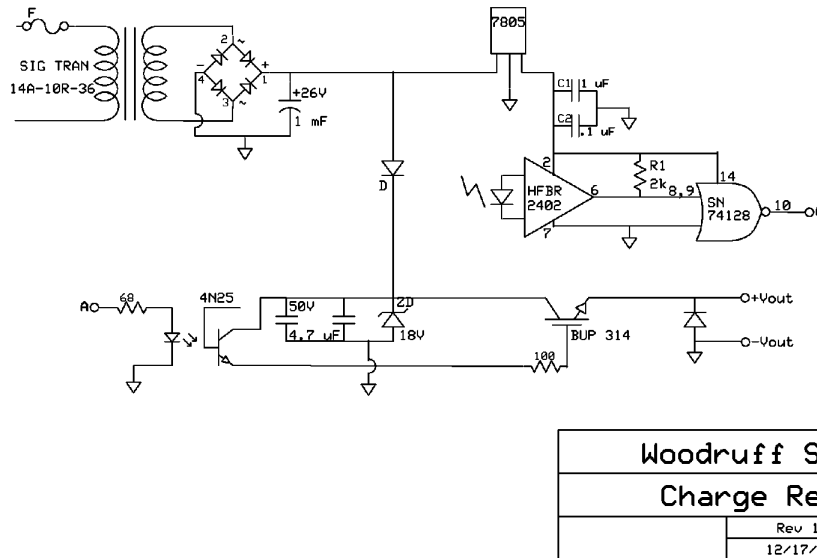

Figure 10: Schematic for charge, dump and ground relay control.

1.15 Environmental requirements

The entire CCDPS is specified to operate at room temperature, and will tolerate seasonal variations in humidity without the need for any special AC, other than cooling lines to the ignitrons. Ideally the banks will be placed in a dust-controlled environment (fans with filters, preferably with drywall to the ceiling) with minimal traffic to the enclosure.

2 References

References

- [1] Statement of Work for Design of Capacitor Charge/Discharge Power Supply (CCDPS) for FLARE FLARE-CCDPS-150828, Revision 0, Sept. 9th 2015

3 Appendices

3.1 Engineering Drawings and Vendor Specifications

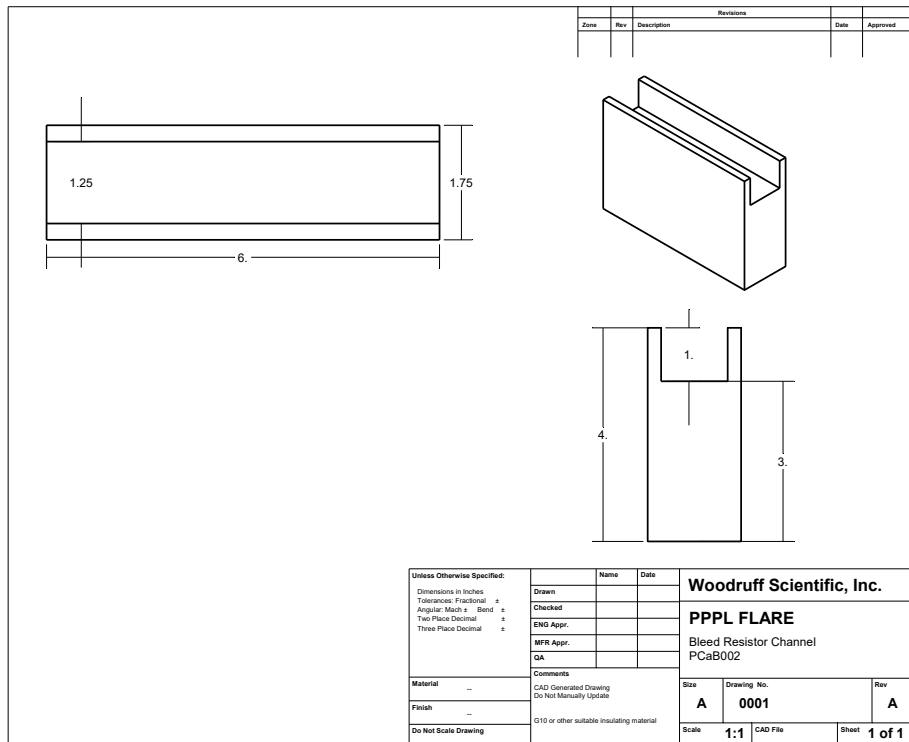

Figure 11: PF Bleed Resistor Channel

	OH	EF	TF	PF
H	8.125	8.125	6.25	6.75
W	10.875	10.875	15	15

Table 2: Bus Clamp Dimensions by Bank (inches)

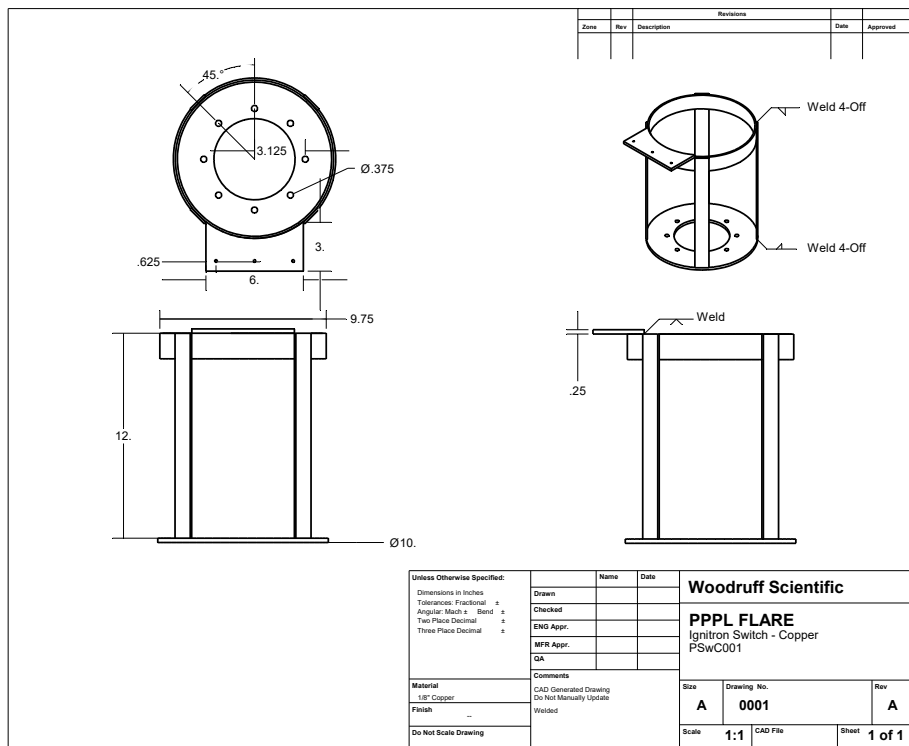

Figure 12: Ignitron Cage - Copper

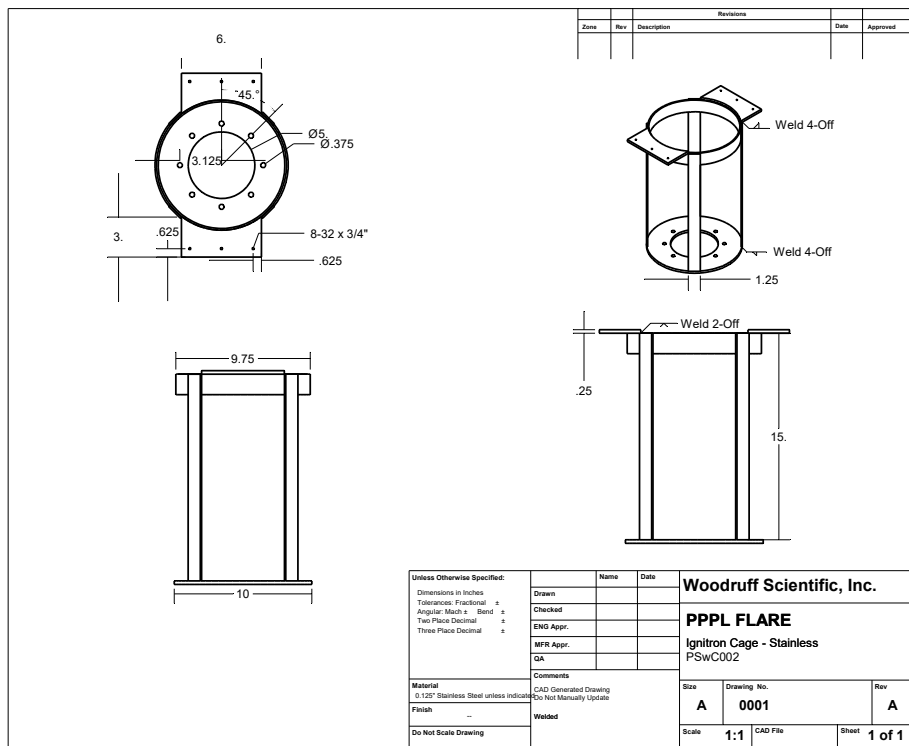

Figure 13: Ignitron Cage - Stainless

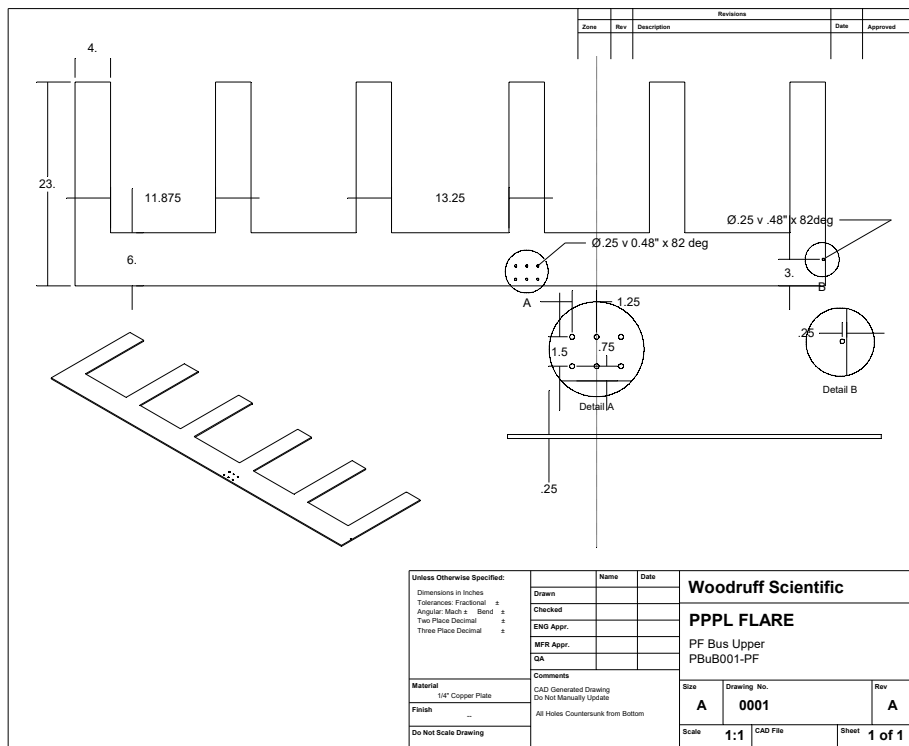

Figure 14: PF Bus Upper

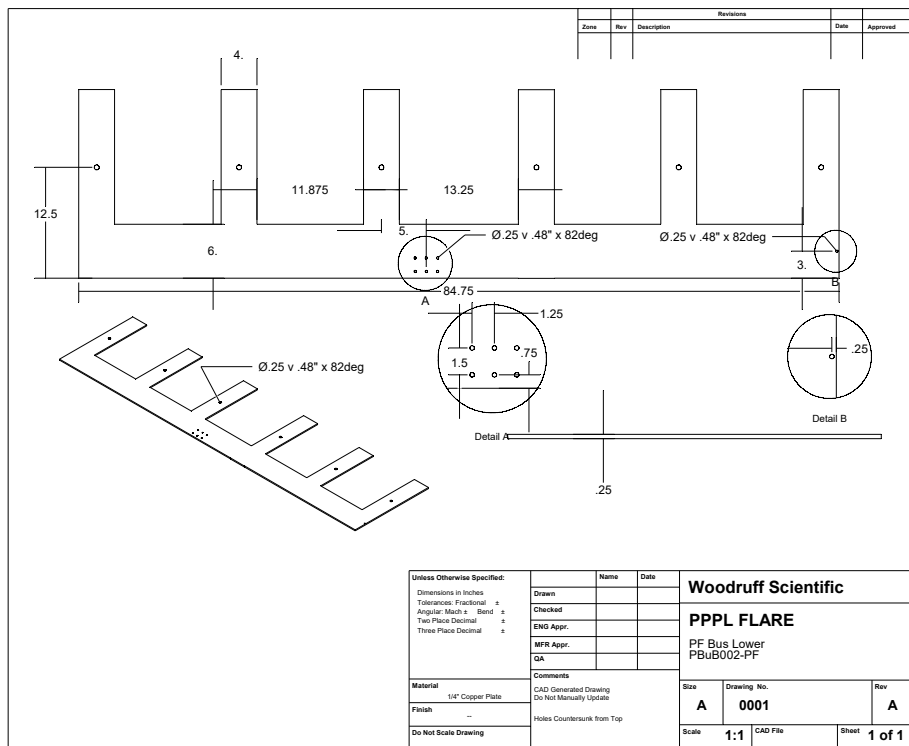

Figure 15: PF Bus Lower

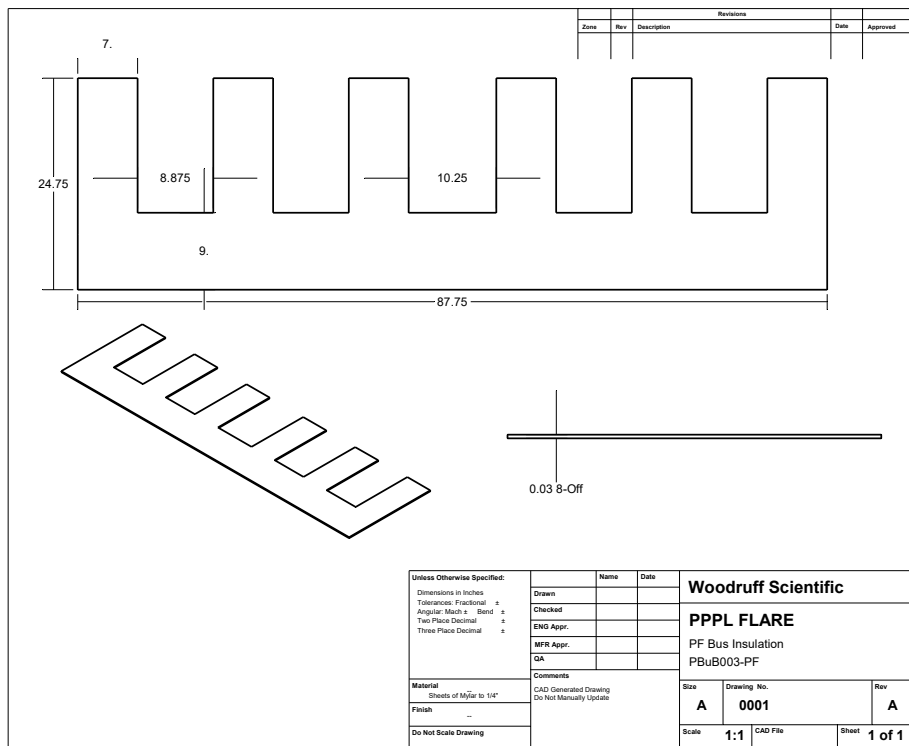

Figure 16: PF Bus Insulation

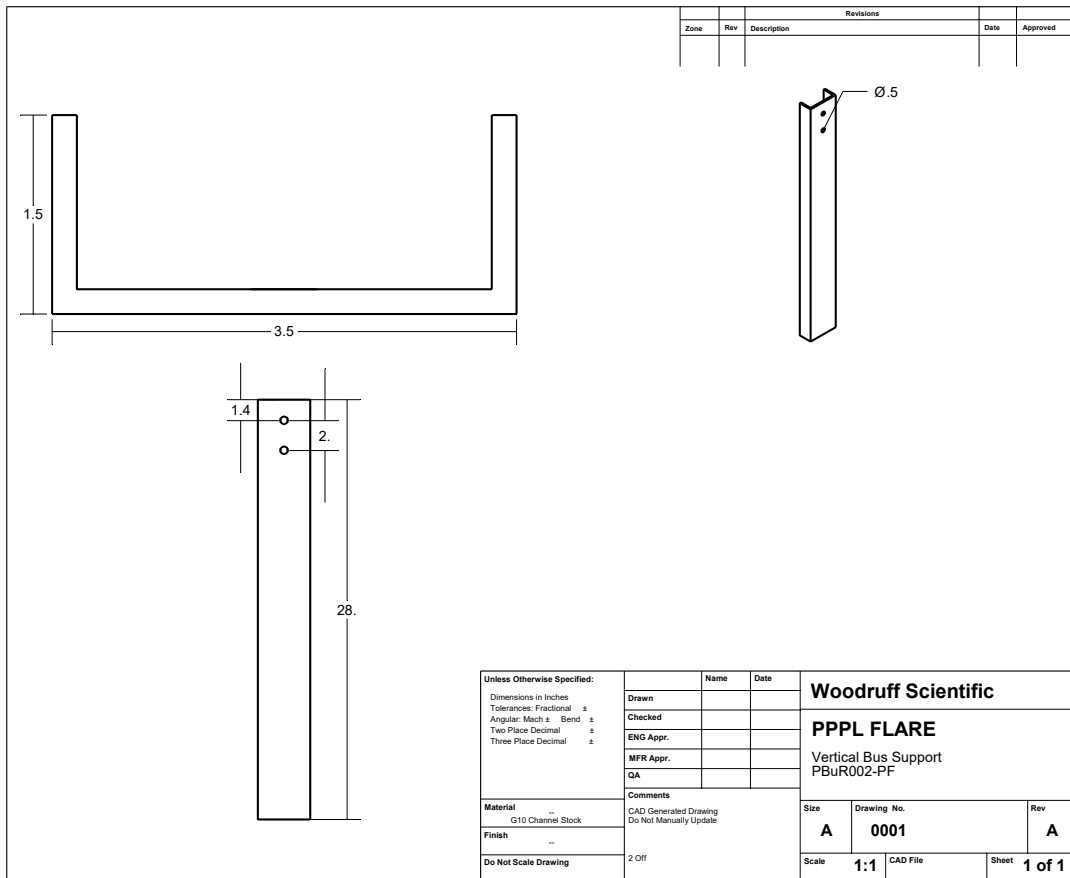

Figure 17: PF Bus Vertical Support - 2 Off

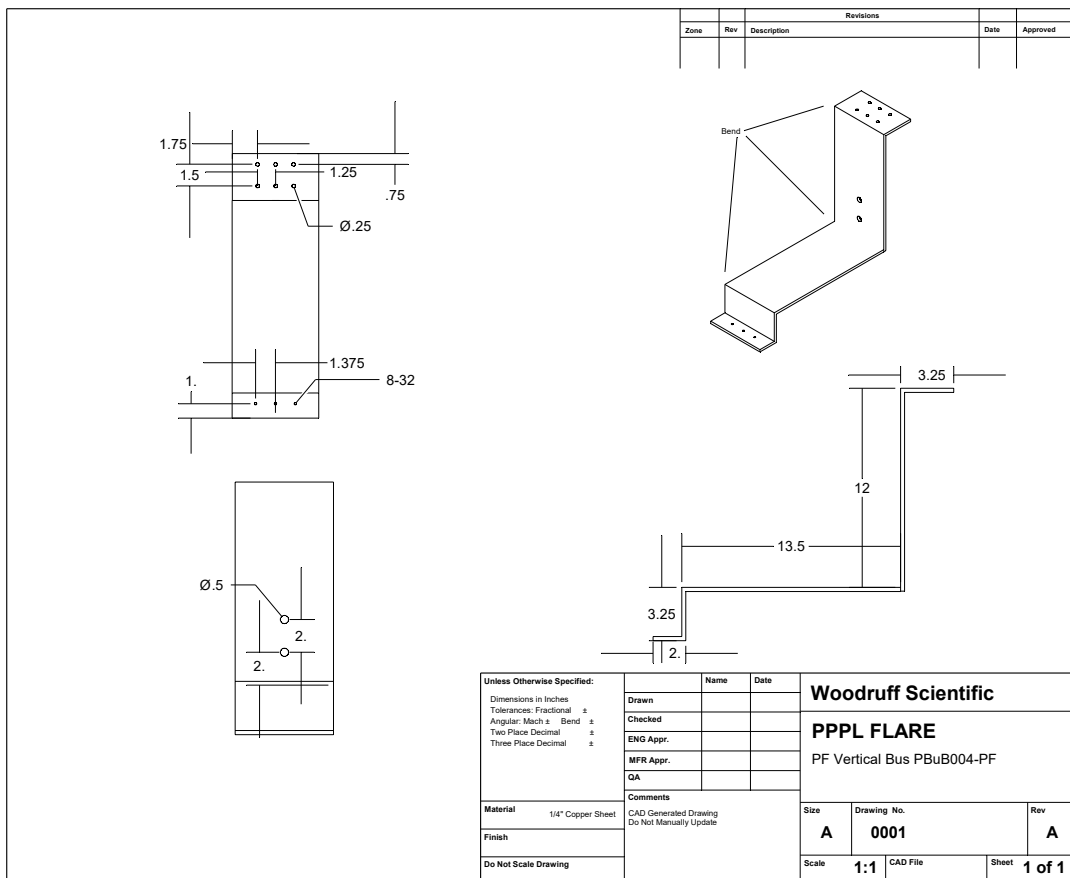

Figure 18: PF Bus Vertical

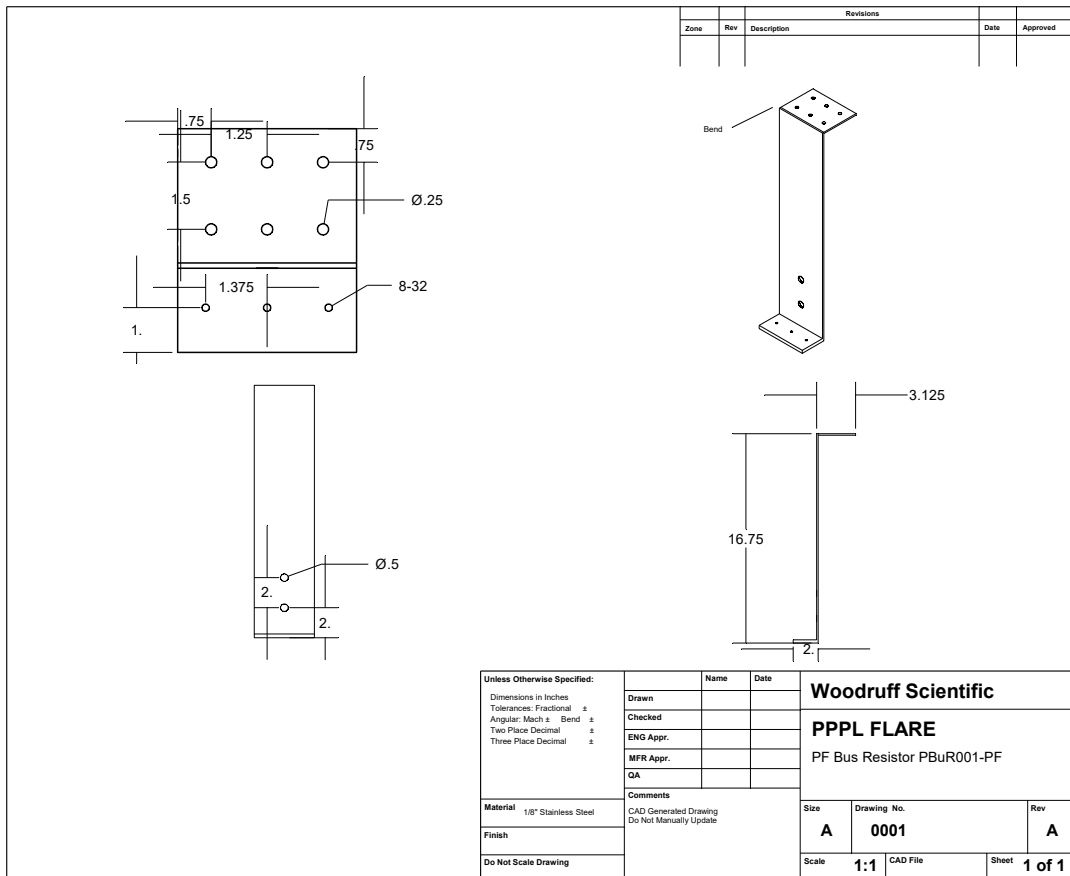

Figure 19: PF Bus Resistor

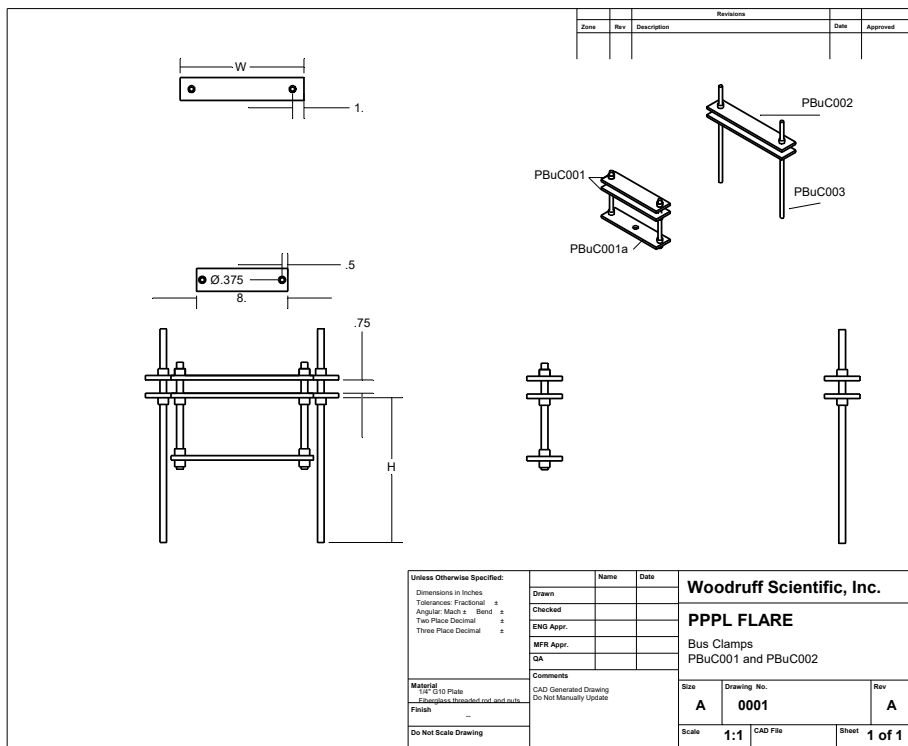

Figure 20: PF Bus Clamps

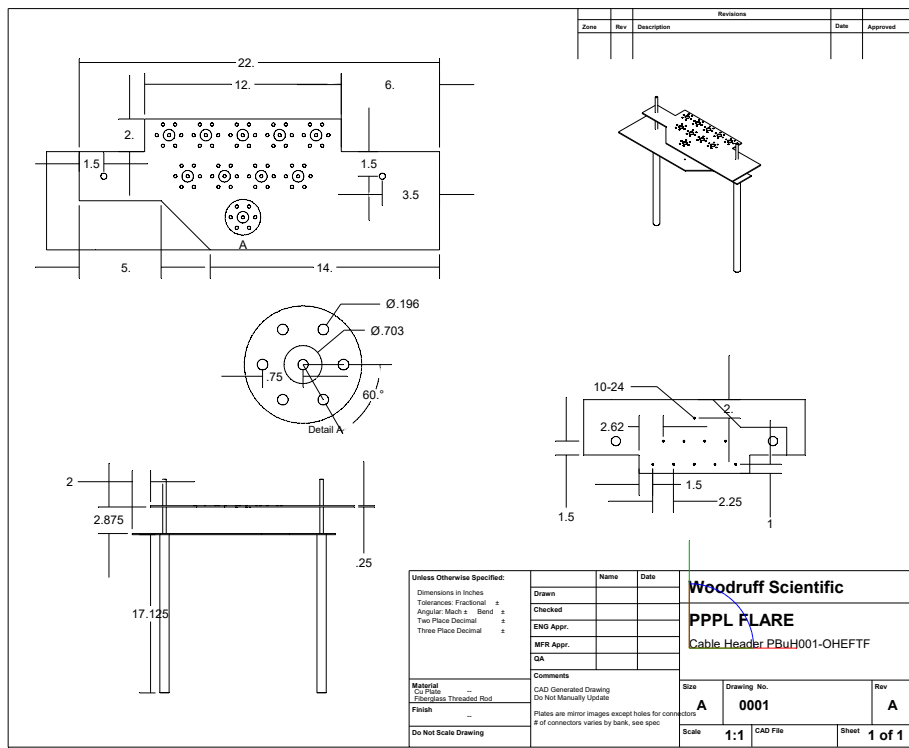

Figure 21: PF Cable Header

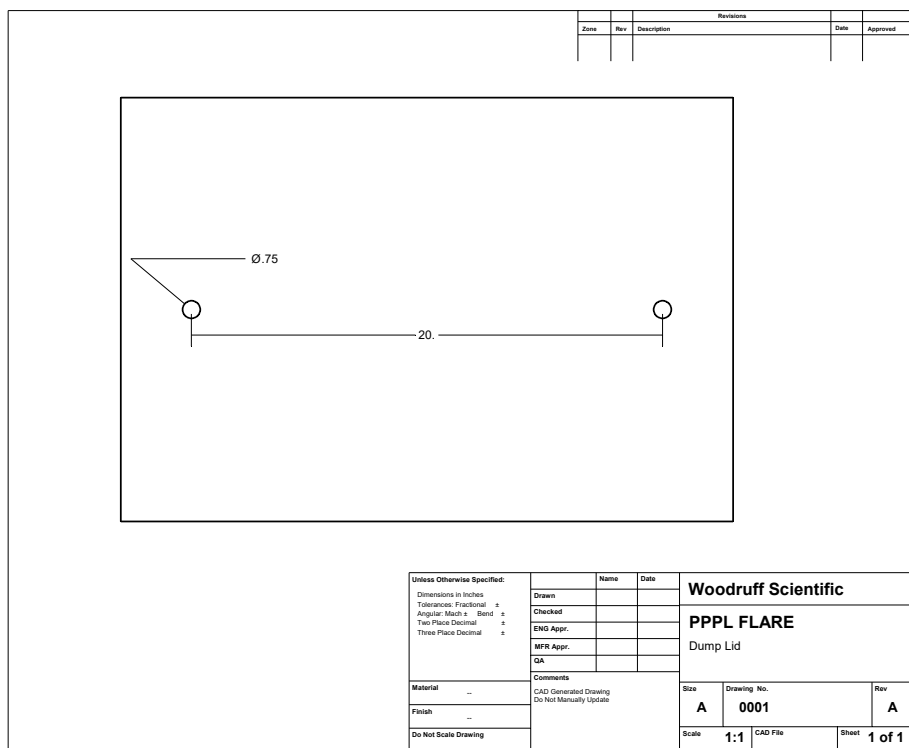

Figure 22: Dump Lid

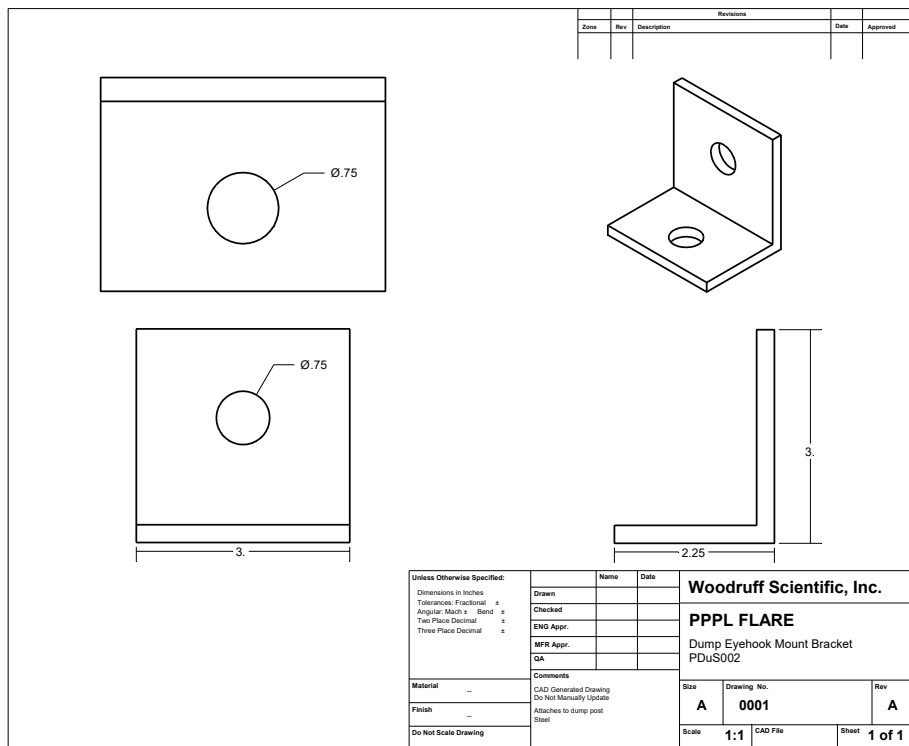
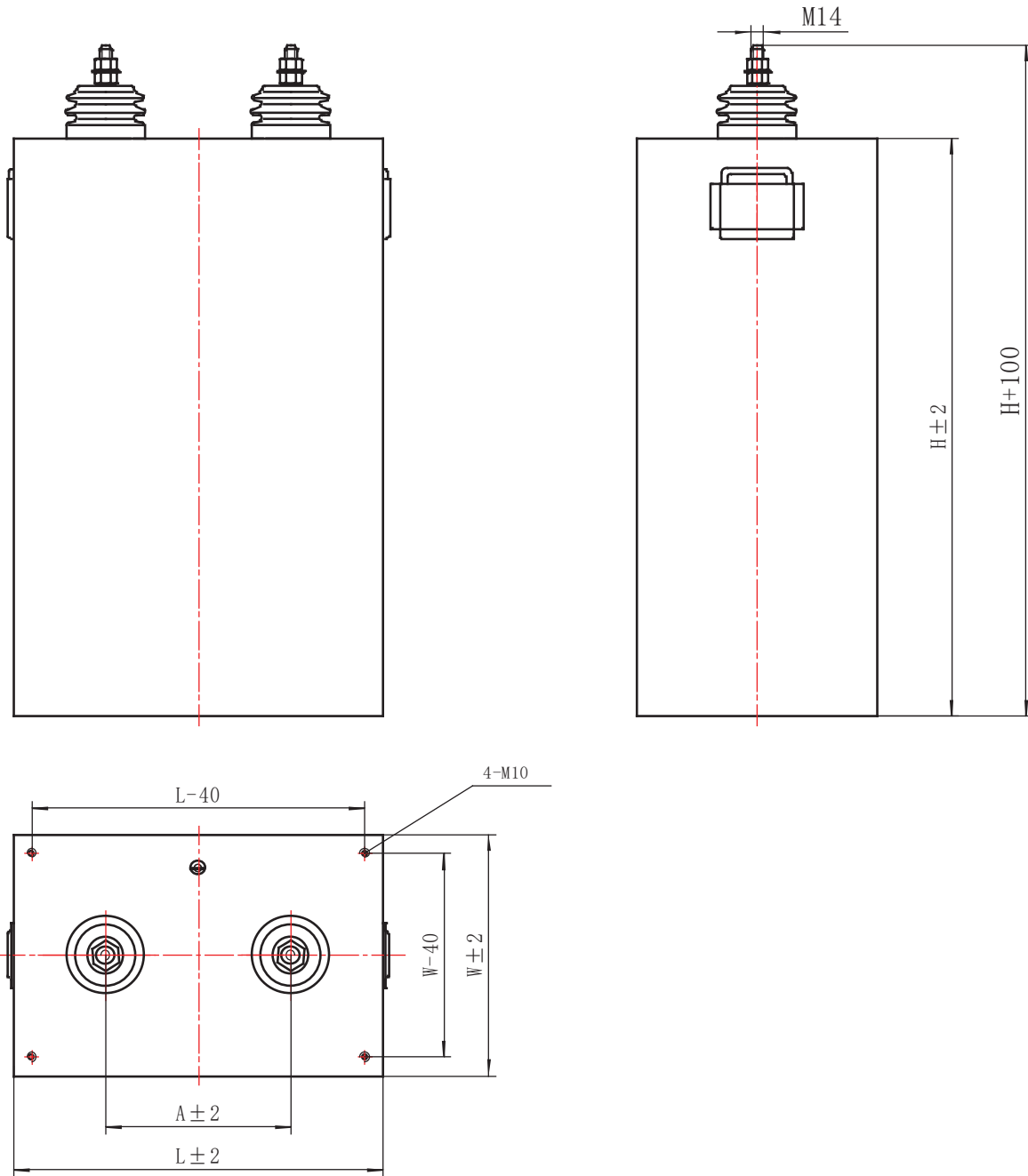

Figure 23: Dump Stick Eyehook Bracket

HDCT 20kV 440 μ F Pulse Capacitor

Type		HDCT
Rated voltage	U_{NDC}	20kVDC
Rated capacitance	C_N	440 μ F
Capacitance tolerance		$\pm 5.0\%$
Rated Discharge Current	I_p	90kA
Max Discharge Current (system fault)	\hat{I}	135kA
Rated Discharge Voltage Reversal	%	95%
Self inductance	L_S	<150 nH
Int. series resistance	R_S	< 8m Ω
Loss factor	$\tan\delta$	< 1.0 x 10 ⁻³ / 100 Hz
Life Expectancy (90 % survival)		500,000 discharges
Operating temperature	$\Theta_{min/ max}$	-40°C / +70 °C
Technology		Metalized Polypropylene film, dry type, SH
Dimensions(mm ³)		418 × 390 × 655



Specification	L (mm)	W (mm)	H (mm)	A (mm)
20kV 440 μ F	418	390	655	220

The NL8900 is a convection cooled ignitron for use as a high energy switch in capacitor discharge circuits. The NL8900 is capable of handling peak voltages of 35 kV and peak currents up to 300 kA.

GENERAL DATA

Electrical:

Cathode Spot Starting	Ignitor
Number of Electrodes	
Anode -----	1
Cathode -----	1
Ignitors -----	2
Inductance (approximate) -----	200 nh

Mechanical:

Envelope -----	Stainless Steel
Anode Material-----	Stainless Steel
Mounting Position -----	Axis Vertical, Anode Up
Net Weight -----	24 lb (10.9 kg)
Diameter -----	7.25"
Seated Height (Nominal) -----	10.75"

Ignitor Ratings:

Voltage	<u>MIN</u>	<u>MAX</u>	
Open Circuit (Ignitor +)	1000	35000	V
Inverse (Ignitor -)	-----	5	V
Current, Short Circuit	500	2000	A
Length of Firing Pulse, 1/2 Sine Wave	5	10	µs

Thermal:

Type of Cooling -----	Liquid
Inlet Water Temperature (MIN) -----	10 °C
Inlet Water Temperature (MAX) -----	30 °C
Water Flow (At MAX Current)-----	3.0 GPM
Cathode Temperature (MAX) -----	35 °C
Anode Header Temperature (MAX) -----	55 °C
Ambient Temperature -----	10 to 30 °C
Anode to Cathode Temperature -----	(Note 1)



July 09, Rev A

Maximum Ratings

	Damped Discharge	Ring Discharge	
Peak Anode Voltage			
Forward -----	35,000 -----	35,000 -----	V
Inverse -----	35,000 -----	35,000 -----	V
Critical Anode Starting Voltage (MIN)	100 -----	100 -----	V
Anode Current			
Peak -----	300,000 -----	300,000 -----	A
Rate of Rise of Current -----	(Note 2) -----	(Note 2) -----	
Discharge (Rep Rate) Typical -----	2 -----	2 -----	Per Minute
Total Charge (Per Minute) -----	250 -----	250 -----	Coulombs
Ionization Time -----	0.5 -----	0.5 -----	µs
Voltage Reversal -----	None -----	100 -----	%



WARNING! USING SIMULTANEOUS MAXIMUM RATINGS WILL SEVERELY DETERIORATE IGNITRON LIFE!

Notes:

- 1) To prevent mercury condensation on the anode and anode seals, the anode header temperature should be 10°C higher than the cathode temperature at all times. Before operation, elevate the temperature of the anode area, with respect to the cathode, long enough to remove any mercury from the top portion of the ignitron.
- 2) Rate of rise depends upon the external circuitry.

Tube Life Considerations

The method used to determine the life expectancy of an ignitron varies according to the application and it is necessary to consider the various types separately. It must be understood that the ratings specified are absolute limits. It is the responsibility of the equipment designer to ensure that the specified limits cannot be exceeded under the worse possible conditions of component tolerance, voltage fluctuation, and load variation.

A general rule of thumb: To obtain longer life, the ignitron must be operated at lower levels. Typically, life may be increased 10X if either the voltage or current is halved.

Ignitrons are robust high current switching devices. The current ratings may be exceeded to some extent without destroying the ignitron but with the consequence of reduced life.

IGNITOR

The ignitor is a small rod of semiconducting material with a pointed end that is partially immersed into the cathode pool. When a suitable current pulse is passed through the ignitor-mercury junction (with the ignitor being positive with respect to the cathode pool) forms a cathode spot on the surface of the mercury and free electrons are emitted. If the anode is sufficiently positive with the cathode at this time, an arc will form between the cathode and anode. Once the arc is initiated, the ignitor has no further control and the ignitron continues to conduct until the voltage across the ignitron falls below the ionization potential of the mercury vapor.

In capacitor discharge circuits the ignitron has to pass a very high current and the conditions are naturally harmful to the ignitron. The mercury pool and the ignitor itself will become contaminated and the best life will be obtained if a high energy pulse is applied to the ignitor. Under these conditions a pulse from a separate excitation circuit containing a 1uf capacitor charged from 1500V to 3000V will provide 1 to 4.5 Joules of energy to the ignitor. Richardson Electronics endorses National Electronics Ignitrons using these parameters. Considering the wide range of ignitors available across the range of ignitrons produced, Richardson Electronics recommends that an ignitor pulse providing 4 to 7 Joules is optimal.

MOUNTING

The performance and life of the ignitron is greatly improved if it is operated in a field free space. Magnetic fields tend to force the arc toward the tube sidewall and aggravate sidewall arcing. Metal vapor produced by sidewall arcing is one of the major contributors to ignitor wetting. We recommend a coaxial type mounting to minimize field effects. See Page 5 for details.

INSTALLATION INFORMATION

RECOMMENDED CONDITIONING BEFORE INITIAL USE - The ignitron is in high voltage operating condition before leaving the factory. Shipping tends to redistribute mercury throughout the ignitron making certain conditioning steps desirable before installation.

Heat Conditioning - Before applying voltage, heat anode stud to 100-125°C (keeping cathode near room temperature) for two hours minimum. This drives mercury away from anode and anode seal area.

Voltage Conditioning (after Heat Conditioning) - Apply 110% of operating voltage (preferably DCV) or up to 110% of rated maximum voltage across ignitron (anode positive and ignitor not connected) with a series combination of a 1 to 4 uf capacitor and a 1 ohm resistor in parallel with the ignitron. NATIONAL will replace any ignitron that will not hold off minimum voltage at initial test when caused by a manufacturing defect. Additional conditioning at higher voltages is recommended to stabilize the ignitron after shipping. Slowly increase voltage above minimum. Breakdown may occur but the ignitron will attain a Hi-Pot Stabilization Voltage of approximately 125% of operating voltage, or up to 125% of rated maximum voltage.

NOTE: The time required for conditioning to Hi-Pot Stabilization Voltage can be reduced by using a variable ac voltage source connected directly across the ignitron (ignitor not connected). Slowly increase the voltage; limit the current to 30 milliamperes maximum.

RECOMMENDED PRACTICE AFTER INITIAL USE - Mercury condensed in the anode and anode seal area greatly decreases the ignitron's voltage hold-off ability. Heat conditioning before initial use complements proper mercury distribution before the ignitron is first placed in operation. Once in operation, maintain a thermal gradient so that the anode area is at least 10°C greater than the cathode. This is also true during any cooling period. The anode and anode area must not cool faster than the cathode.

The ignitor becomes susceptible to damage by movement of mercury after use in a capacitor discharge or crowbar application. For maximum life, we recommend that an ignitron not be moved until end-of-life once it has been placed in service.

LIFE AND WARRANTY

Richardson Electronics, Ltd. warrants the tube types listed above to be free from defects of design, material, and workmanship when received and, after receiving Recommended Conditioning Before Initial Use, to operate satisfactorily when first installed and, if used within ratings, to give a minimum of 1000 operations. No adjustment will be made if the tube is not placed in service within six months after date of shipment by manufacturer. This warranty expires 12 months after date of shipment by manufacturer.

National High Voltage Switching Ignitrons have an expected life of many times the warranted number of operations in most applications. Operating within the recommended ratings and following the *Recommended Practices After Initial Use* will greatly increase the life or operations obtained.

AVAILABLE ACCESSORIES

Part Number	Description
1K958-Series	Ignitor Tulip Clip/Cable Assembly (Various options available, check with your local Richardson representative for details.)
IG5F2-10	Ignitor Trigger Module (Works on all National Ignitrons.)

OUTLINEDRAWING

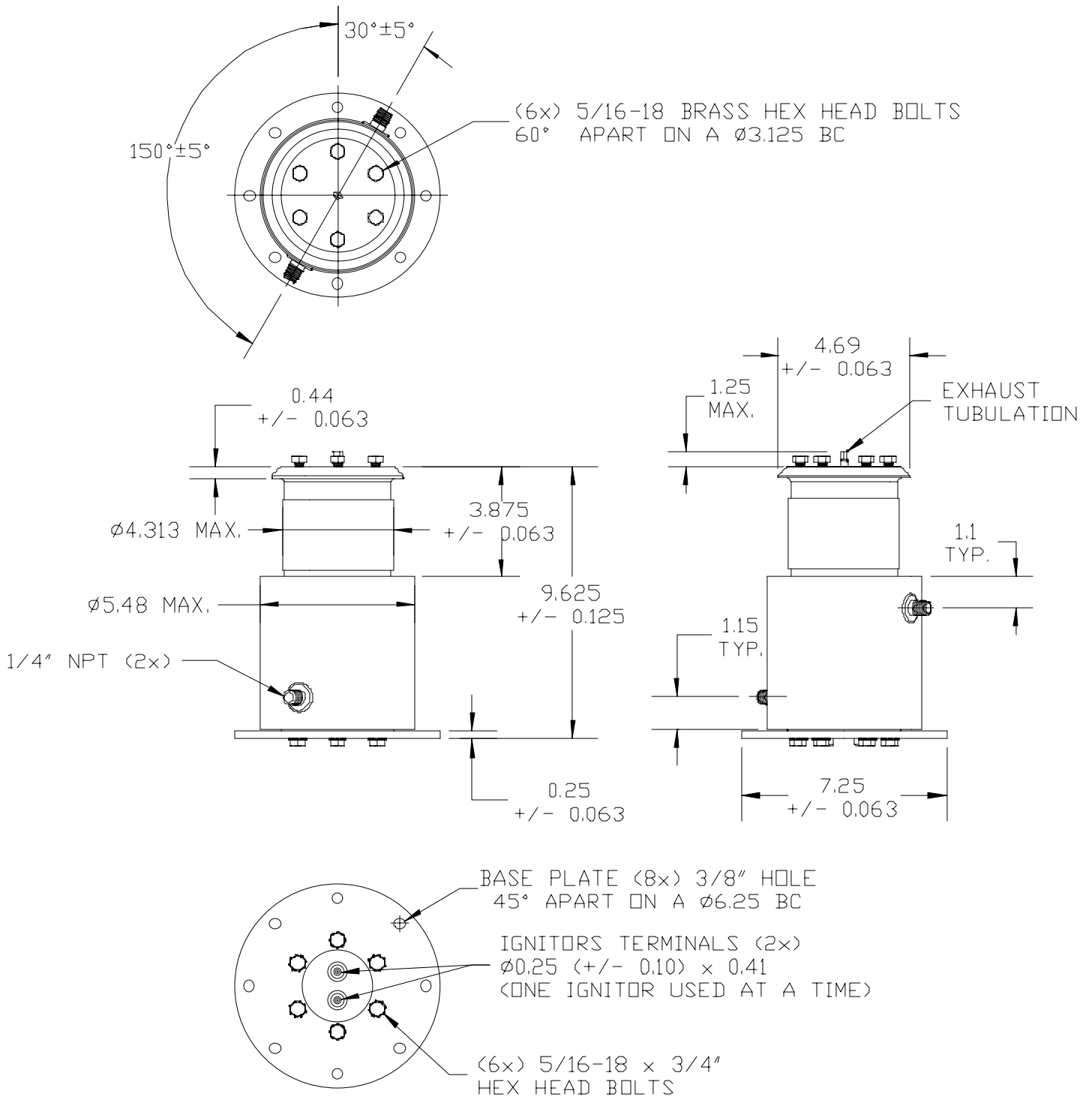

NOTE: The mounting flange attached to the bottom of the tube can be modified in most cases for compatibility with the users socket. In all cases coaxial returns "squirrel cages" are recommended. The anode contact must NOT be ridged with respect to the cathode and the flexible anode connection MUST absorb all buss bar movement.



IG5F2-10 Ignitron Driver Manual

Serial Number _____

Test V open _____

Test I short w/protection: _____

Test I short w/o protection: _____

Life Test Start _____

Life Test Finish _____



Phone 800-348-5580
FAX 630-208-2553

1. General

The IG5F2-10 Ignitron driver is designed to meet the specifications for triggering all ignitrons. It also provides a trigger isolation capability of 25 kV. Its specifications are:

Stored Energy:	4 Joule at 1.0 Hz.; 3 J at 2 Hz.
Open Circuit Voltage:	1.80 kV at 1.0 Hz.
Current:	370 A output into typical ignitron ignitor (1 Hz.)
AC Input Voltage:	100 - 125 VAC input or 200 - 250 VAC input using internal slide switch. Failure to set the unit properly when using the higher voltage will destroy the unit.
Input Pulse:	5 V TTL if fiber optic transmitter accessory board is used Note that most 5 - 10 mA sources will drive this with 3 m cable.
Input Pulse Duration:	3 - 100 usec
Output Voltage Isolation:	25 kV to the input voltage
Fuse:	1/4 A internal
Supplied Fiber:	10 m. standard HP Versatile Fiber Type
Trigger Delay:	1200 ns. Typical
Status Indicators:	TRIG TEST (See figures for TRIG TEST output characteristics) PS STATUS
Storage Temperature:	-20 C - 45 C
Operating Temperature	5C - 40 C

2.0 Installation

Connect a versatile fiber trigger signal to the input fiber optic. The BNC/fiber adapter may be used to supply the trigger to the unit by applying a 5 - 15 V pulse to the BNC. TTL signals which meet typical TTL requirements will trigger the unit (5 V, 5 mA).

Connect the output marked "Ignitor" to the Ignitor pin, and connect the output marked "Cathode" to the cathode. These connections should be secure and capable of conducting 400 A pulsed.

Open the unit and check the internal switch to assure that the power is set to the type of power line you plan to use. **If the internal power switch is not set correctly the unit may fail.** The factory setting is always for 220 VAC. Connect the input power (220 VAC nominal or 110 VAC nominal) to the AC receptacle once the settings of both switches are assured. If a powered trigger module has been supplied, check the settings of that unit before use.

Pulse the unit. Check the connections without HV applied to the ignitron to make sure that the contacts are not arcing. The unit will make an audible “ticking” noise when triggered.

3.0 Mounting

A template for mounting the unit is appended. Studs used are Metric system M8.

4.0 Applications

The IG5-F is an ignitron driver supplied with the capability for isolation of the output. For circuits where the cathode is floating, such as series ignitron applications, the circuit can derive power from the external circuit:

Circuit A Recommended Wherever Possible

In circuit A, the cathode of the ignitron is grounded. If this circuit can be used, cooling of the ignitron jacket is simplified, along with triggering and monitoring. The unit power is connected to line voltage, the fiber is inserted into the driver, and the unit triggers with each light pulse. The input power ground should be grounded (IEC plug and chassis ground).

Circuit B Lower Value Biases

In circuit B, the cathode of the ignitron is at some potential up to 25 kV from ground. If this circuit can be used, heating of the anode insulator is simplified, along with triggering and monitoring. The unit power is connected to line voltage, the fiber is inserted into the driver, and the unit triggers with each light pulse. An MOV of appropriate voltage connected from either of the line voltages (preferably neutral if such exists) to the preferred earth ground may be desirable. No voltage can exceed 25 kV relative to ground. The input power ground should be grounded (IEC plug and chassis ground).

Circuit C Floating Ignitron Powered by AC

In circuit C the circuit derives its power from AC voltage, but neither the cathode or anode is grounded. The voltage difference between the cathode/ignitor and anode must not exceed 25 kV including during transients. No voltage can exceed 25 kV relative to ground.

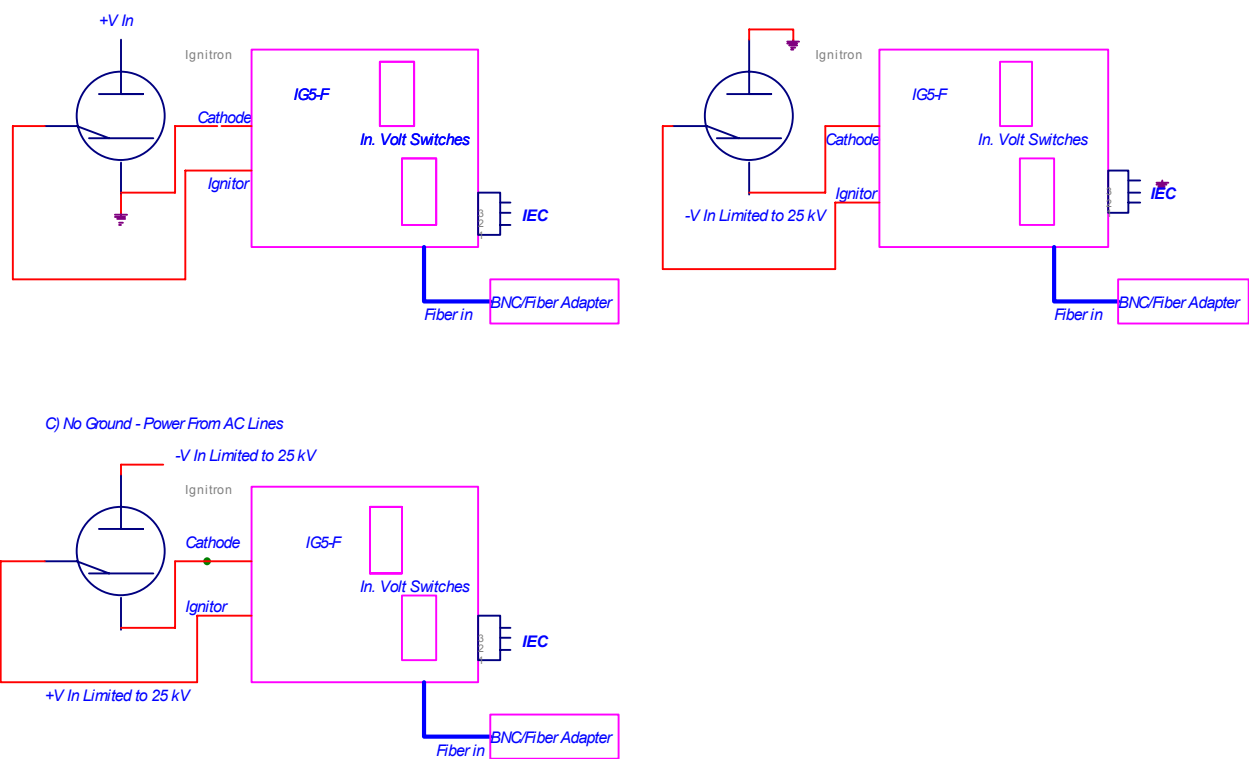

Figure 1 Application scenarios. The metal box should always be grounded.

5.0 Mounting

All parts are mounted to the enclosure. In order to mount the box, drill holes as described in the appended print, or use the template supplied.

6.0 Grounding

The box is designed for grounded operation. If floating operation is necessary, the signal source and power source must be floated to the same potential. The difference between the power voltage and the box voltage should not exceed 700 V peak.

7.0 Power Supply Voltage Monitor

The monitor labeled PS Status has an output when the power supply driving the SCR is “ready”. This will fail to light if the 600 V internal power supply or SCR fails.

Figure of TRIG TEST output characteristic

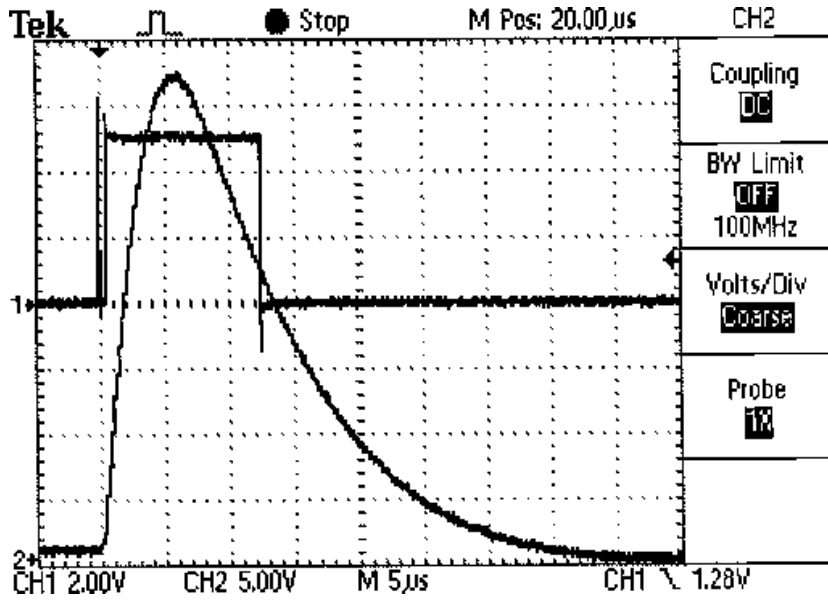

Fig. 2 Short Circuit Monitor and Current.

Figure 2 shows the current in the output along with the monitor output for the case where the ignitron ignitor fires immediately. The monitor is on for 10 - 15 microseconds and its main pulse starts within 2 microseconds of trigger initiation. This corresponds to nominally good performance.

Figure 3 shows the open circuit/open ignitor case. A pulse after saturation of the transformer, delayed by approximately 5 microseconds. In most situations, the pulse should appear in 4 microseconds or less time after initiation of the pulse from the fiber.

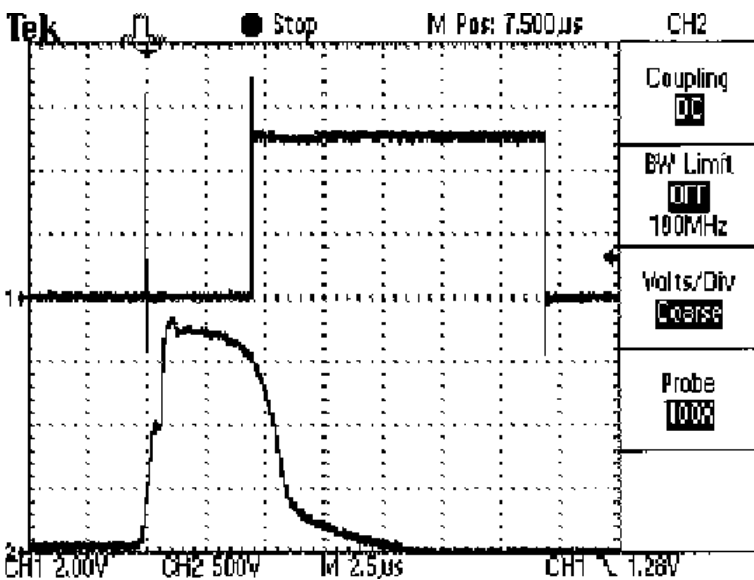

Fig. 3 monitor and open circuit voltage

SPECIFICATIONS IG5F2-10

The IG5F2-10 Ignitron driver is designed to meet the specifications for triggering all ignitrons. It also provides a trigger isolation capability of 25 kV. Its specifications are:

Stored Energy:	4 Joule at 1.0 Hz.; 3 J at 2 Hz.
Open Circuit Voltage:	1.80 kV at 1.0 Hz.
Current:	370 A output into typical ignitron ignitor (1 Hz.)
AC Input Voltage:	100 - 125 VAC input or 200 - 250 VAC input using internal slide switch. Failure to set the unit properly when using the higher voltage will destroy the unit.
Input Pulse:	5 V TTL if fiber optic transmitter accessory board is used Note that most 10 mA sources will drive this with 3 m cable. Longer cables will require more current
Input Pulse Duration:	3 - 100 usec
Output Voltage Isolation:	25 kV to the input voltage
Fuse:	1/8 A internal - 220 VAC; 1/4A internal 110 VAC
Supplied Fiber:	10 m. standard HP Versatile Fiber Type
Trigger Delay:	1200 ns. Typical
Status Indicators:	TRIG TEST (See figures for TRIG TEST output characteristics) PS STATUS

NOTES:

IG-5-F-T2 Ignitron/Thyratron Driver Multiple Trigger Output Accessory

The IG-5-F-T4 is a 2 output trigger driver for North Star Ignitron and Thyratron drivers. It consists of a BNC high impedance input, a pulse amplifier, and 4 trigger output channels. The specifications are:

Power Supply Input Voltage: 100 - 260 V
(Note: Power Supply is CE marked)
Input Power Connection Standard IEC320 as used on most computers

Input Voltage: 2.4 V "on" 0.8 V "off"
Input Voltage: 15 V max
Input Current: 10 uA
Input Pulse Duration: 100 ns. Minimum

Output Pulse Power 5 dbm
Output Power Risetime Max. 85 ns.
Output Pulse Duration Input pulse duration- 30 ns. min
Output Delay Time 75 ns. typical
Output Power Peak Wavelength 650 nm.

Output Fiber Specification

Type: Plastic
Diameter 1 mm
Brand Hewlett Packard
Part Number HP 3510 Simplex or HP 3610 Duplex

Notes on cable: **Do not bend Fiber Optic Cable with a radius of curvature of less than 4 cm.** The light signal drops significantly for tight bends.

Application

The unit is designed to simultaneously trigger multiple ignitrons or thyatron. The unit should be connected to a TTL or higher input voltage (15 V Max.). It produces an output pulse of the same duration.

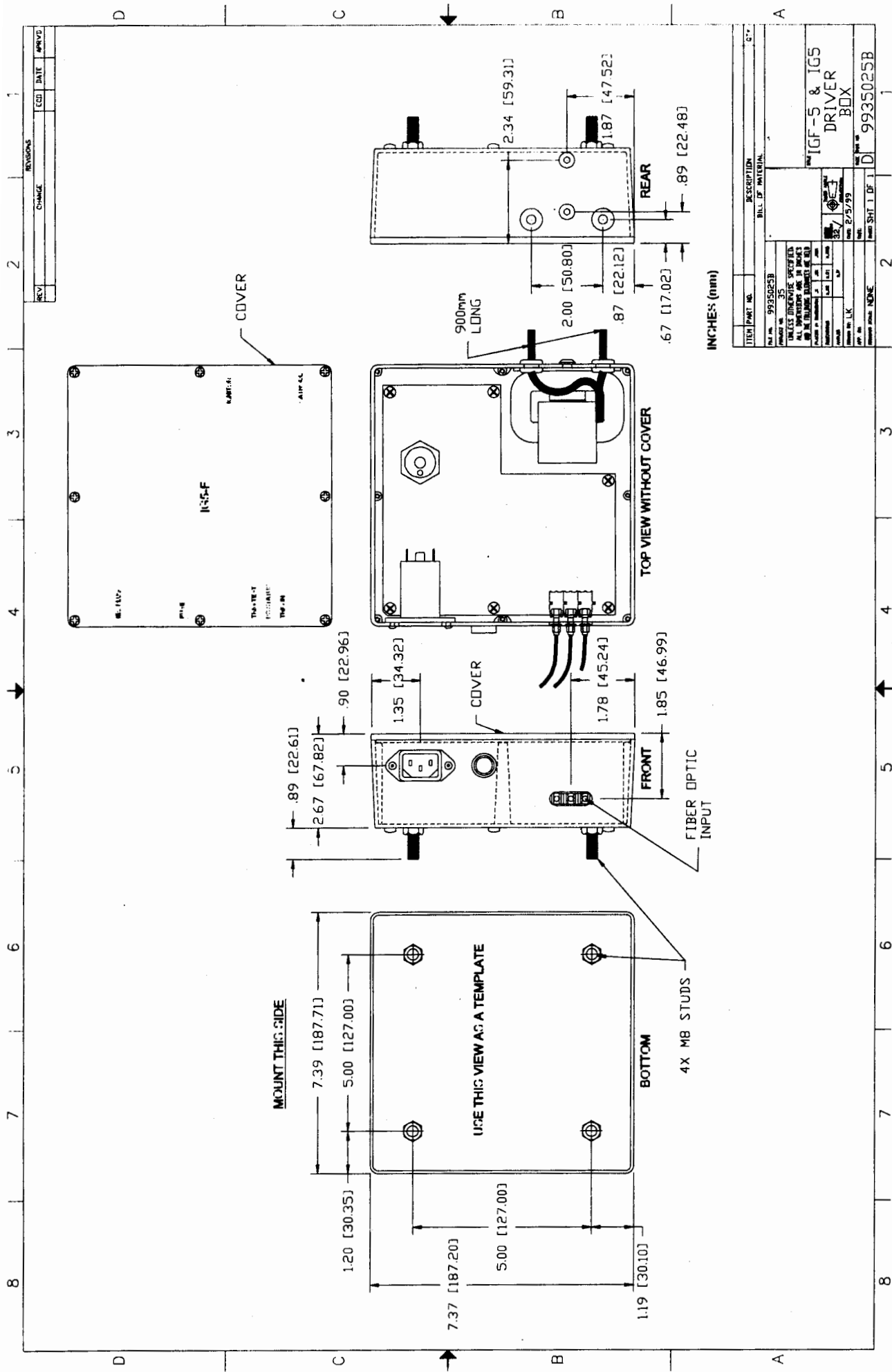

ITEM PART NO.	DESCRIPTION	BILL OF MATERIAL
9935025B	IGF-5 & IGS DRIVER BOX	
35	TRACES (DRIVER) SEE P. 114	
36	ALL DIMENSIONS ARE IN INCHES	
37	ALL DIMENSIONS ARE IN MILLIMETERS	
38	ALL DIMENSIONS ARE IN MILLIMETERS	
39	ALL DIMENSIONS ARE IN MILLIMETERS	
40	ALL DIMENSIONS ARE IN MILLIMETERS	
41	ALL DIMENSIONS ARE IN MILLIMETERS	
42	ALL DIMENSIONS ARE IN MILLIMETERS	
43	ALL DIMENSIONS ARE IN MILLIMETERS	
44	ALL DIMENSIONS ARE IN MILLIMETERS	
45	ALL DIMENSIONS ARE IN MILLIMETERS	
46	ALL DIMENSIONS ARE IN MILLIMETERS	
47	ALL DIMENSIONS ARE IN MILLIMETERS	
48	ALL DIMENSIONS ARE IN MILLIMETERS	
49	ALL DIMENSIONS ARE IN MILLIMETERS	
50	ALL DIMENSIONS ARE IN MILLIMETERS	
51	ALL DIMENSIONS ARE IN MILLIMETERS	
52	ALL DIMENSIONS ARE IN MILLIMETERS	
53	ALL DIMENSIONS ARE IN MILLIMETERS	
54	ALL DIMENSIONS ARE IN MILLIMETERS	
55	ALL DIMENSIONS ARE IN MILLIMETERS	
56	ALL DIMENSIONS ARE IN MILLIMETERS	
57	ALL DIMENSIONS ARE IN MILLIMETERS	
58	ALL DIMENSIONS ARE IN MILLIMETERS	
59	ALL DIMENSIONS ARE IN MILLIMETERS	
60	ALL DIMENSIONS ARE IN MILLIMETERS	
61	ALL DIMENSIONS ARE IN MILLIMETERS	
62	ALL DIMENSIONS ARE IN MILLIMETERS	
63	ALL DIMENSIONS ARE IN MILLIMETERS	
64	ALL DIMENSIONS ARE IN MILLIMETERS	
65	ALL DIMENSIONS ARE IN MILLIMETERS	
66	ALL DIMENSIONS ARE IN MILLIMETERS	
67	ALL DIMENSIONS ARE IN MILLIMETERS	
68	ALL DIMENSIONS ARE IN MILLIMETERS	
69	ALL DIMENSIONS ARE IN MILLIMETERS	
70	ALL DIMENSIONS ARE IN MILLIMETERS	
71	ALL DIMENSIONS ARE IN MILLIMETERS	
72	ALL DIMENSIONS ARE IN MILLIMETERS	
73	ALL DIMENSIONS ARE IN MILLIMETERS	
74	ALL DIMENSIONS ARE IN MILLIMETERS	
75	ALL DIMENSIONS ARE IN MILLIMETERS	
76	ALL DIMENSIONS ARE IN MILLIMETERS	
77	ALL DIMENSIONS ARE IN MILLIMETERS	
78	ALL DIMENSIONS ARE IN MILLIMETERS	
79	ALL DIMENSIONS ARE IN MILLIMETERS	
80	ALL DIMENSIONS ARE IN MILLIMETERS	
81	ALL DIMENSIONS ARE IN MILLIMETERS	
82	ALL DIMENSIONS ARE IN MILLIMETERS	
83	ALL DIMENSIONS ARE IN MILLIMETERS	
84	ALL DIMENSIONS ARE IN MILLIMETERS	
85	ALL DIMENSIONS ARE IN MILLIMETERS	
86	ALL DIMENSIONS ARE IN MILLIMETERS	
87	ALL DIMENSIONS ARE IN MILLIMETERS	
88	ALL DIMENSIONS ARE IN MILLIMETERS	
89	ALL DIMENSIONS ARE IN MILLIMETERS	
90	ALL DIMENSIONS ARE IN MILLIMETERS	
91	ALL DIMENSIONS ARE IN MILLIMETERS	
92	ALL DIMENSIONS ARE IN MILLIMETERS	
93	ALL DIMENSIONS ARE IN MILLIMETERS	
94	ALL DIMENSIONS ARE IN MILLIMETERS	
95	ALL DIMENSIONS ARE IN MILLIMETERS	
96	ALL DIMENSIONS ARE IN MILLIMETERS	
97	ALL DIMENSIONS ARE IN MILLIMETERS	
98	ALL DIMENSIONS ARE IN MILLIMETERS	
99	ALL DIMENSIONS ARE IN MILLIMETERS	
100	ALL DIMENSIONS ARE IN MILLIMETERS	



402 Series Data Sheet
High Voltage Power Supply
Capacitor Charging and DC
Output Voltage from 1kV - 50kV
Output Power 4kJ/sec or 4kW
Full local and remote control



TDK-Lambda

www.us.tdk-lambda.com/hp

402 Series Specification

Industry standard rack mount capacitor charging and DC power supplies with 4kJ/sec rating for capacitor charging, or 4kW rating in continuous DC applications.

- Power rating of 4kJ/sec, 5kJ/sec peak
- Output Voltages from 0-1kV to 0-50kV
- Compact air cooled rack mount package
- Efficient IGBT based resonant inverter
- Excellent pulse to pulse repeatability
- 208 or 400VAC 3Ø input voltage
- Comprehensive remote control interface
- UL Approved AC line contactor (optional for OEM models)
- Ultra reliable and rugged industry standard design
- Passive PFC (pf = 0.85)
- Full local output voltage and HV On/Off controls (L version)
- Simple parallel operation for higher power
- Lab, Slave, or OEM front panel options

Average Capacitor Charging Power	4,000 Joules/sec ($\frac{1}{2}CV^2 \times \text{Rep Rate}$)
Peak Capacitor Charging Power	5,000 Joules/sec ($\frac{1}{2}CV^2/t_{\text{charge}}$)
Average Continuous DC Power	4,000 Watts
Output Voltage Range	1, 2, 4, 5, 10, 15, 20, 30, 40, 50kV, variable from 10-100% of rated
Polarity	Available as fixed Positive or Negative. Please specify at time of ordering
HV Output Cable	1-39kV Models - DS2124 Coaxial cable with proprietary HV connector 40-50kV Models - DS2214 Coaxial cable with proprietary HV connector
HV Insulating Medium	Exxon Mobil Univolt N61B or equivalent insulating oil
AC Input Voltage	208VAC (180-264), 3Ø or 400VAC (340-460), 3Ø + N, specify at time of ordering
AC Input Current	20A/15A
AC Connector	UL/CSA approved terminal block. 3Ø + $\frac{1}{2}$ for 208VAC, 3Ø + N + $\frac{1}{2}$ for 400VAC
AC Line Contactor	UL/CSA approved AC line contactor (standard on 402L and 402S, option for 402OEM)
Power Factor	Passive PFC pf = 0.85 at full load and nominal AC line
Efficiency	Better than 85% at full load
Front Panel	402L - Voltage Control, Voltage & Current Meters, Status Indicators 402S - On/Off Switch, Status Indicators 402-OEM - Blank front panel
Stability	0.2% per hour after 1 hour warmup
Temperature Coefficient	100ppm per °C typical
Stored Energy	Less than 0.3J all models
Pulse to Pulse Repeatability	±2% to 1000Hz, consult factory for higher rep rates
Dimensions - inches (mm)	19 (483) W x 7 (178) H x 17 (432) D
Weight - lbs (kg)	65 (30)
Ambient Temperature	Storage: -40 to +85°C. Operating: -20 to +45°C
Altitude	Storage: 40,000ft (12,000m), Operating: 9,900ft (3,000m)
Humidity	10-90%, non-condensing
Protection	Open/short circuits, Overloads, Arcs, Overtemp, Overvoltage, Safety Interlock
Remote Control (all models)	Via 25-pin D-sub connector on rear of unit, Signals include, Vprogram (0-10V), HV Enable/Reset, Inhibit, Summary Fault, Load Fault, Vanalog, Vpeak
Accessories	10ft HV cable, operating manual
Options	EN - Low Enable. Replaces standard high enable 5V - 0-5V Analog programming. Replaces standard 0-10V programming. LP - Latching Overload Protection, requires HV reset after overload fault DC - Continuous DC operation CT - AC line contactor (option for 402OEM models only, standard on 402L and 402S) Double terminated HV cable, and mating bulkhead connector
Ordering Info	Model - XXkV - POS (or NEG) - YYYYVAC - ZZ (options)
Ordering Examples	402L-10kV-POS, 402S-1kV-NEG-DC, 402-OEM-50kV-POS-400VAC
All specifications subject to change without notice	

402 Series Mechanical Details

402L Front View



- 1 - HV On/Off Push Buttons (L model only)
- 2 - Status Indicator LEDs (L and S models only)
- 3 - Local/Remote Keyswitch (L model only)
- 4 - 10-Turn HV Output Control (L models only)
- 5 - View Set Push Button (L models only)
- 6 - Output Voltage and Current Displays (L models only)
- 7 - Power Switch (L and S models only)

402L Rear View

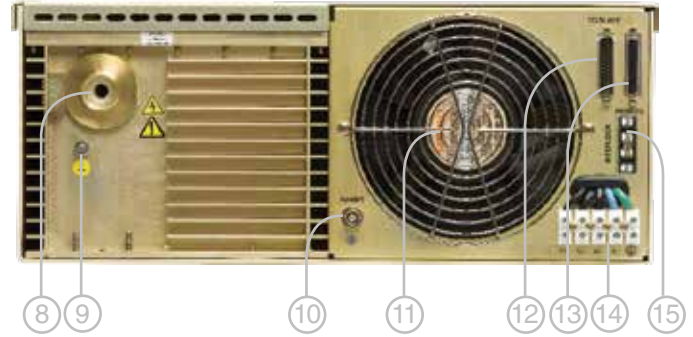

- 8 - HV Output Connector
- 9 - Ground Stud
- 10 - Inhibit BNC (L models only)
- 11 - Cooling Fan
- 12 - Slave Supply Programming Connector (L models only)
- 13 - Remote Programming Connector
- 14 - AC Input Terminal Block
- 15 - Interlock Terminals (L and S models only)

Outline Drawings

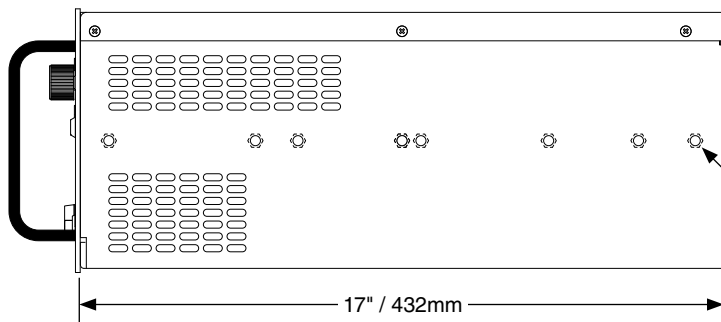
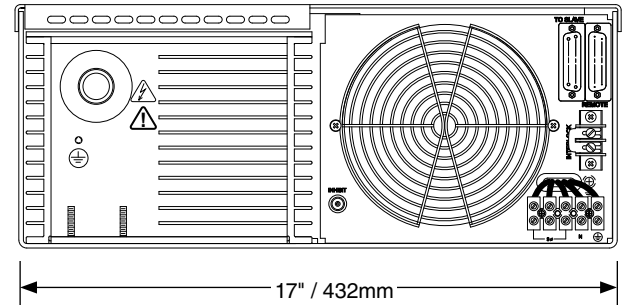
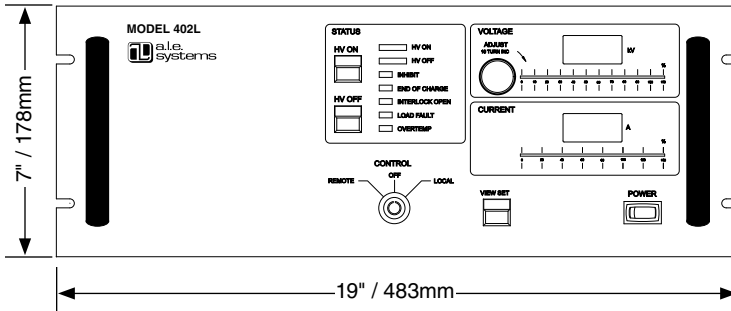

Chassis slide mounting holes

Notes:

- 1 - Chassis slide mounting pattern matches General Devices CT series or equivalent with 3.875" hole spacing.
- 2 - Cooling air enters rear of unit and exits at either side. Do not block air vents or cooling fan and allow several inches of clearance at rear of unit.
- 3 - Allow 6" bend radius at rear of unit for HV cable.

GLOBAL HIGH VOLTAGE NETWORK

NORTH AMERICA

TDK-Lambda Americas Inc., High Power Division
405 Essex Rd. Neptune, NJ 07753
Tel: +1-732-922-9300, Fax: +1-732-922-1441
E-mail: andy.tydeman@us.tdk-lambda.com
Web: www.us.tdk-lambda.com/hp

CANADA

TMetrix
5805 Kennedy Road Mississauga,
Ontario L4Z 2G3
Tel: +1-905-890-2010, Fax: +1-905-890-1959
E-mail: lambda@aca.ca, Web: tmetrix.com

UK

Pulse Power & Measurement Ltd.
65 Shrivenham Hundred Business Park
Watchfield, Swindon
Wiltshire, SN6 8TY
Tel: +44-1793-784389, Fax: +44-1793-784391
Email: sales@ppm.co.uk, Web: www.pmpower.co.uk

IRELAND

FRANCE

TDK-Lambda France
ZAC des Delaches CS 41077, 9 rue Thuillere
91978 Villebon Courtaboeuf
Tel: +33 1 60 12 71 65, Fax: +33 1 60 12 71 66
Email: france@fr.tdk-lambda.com
Web: www.fr.tdk-lambda.com

BELGIUM

SPAIN

NETHERLANDS

LUXEMBOURG

GERMANY

Guth GmbH
Spitzenbergstrasse 6
D – 73084 Salach
Tel: +49-7162-948930, Fax: +49-7162-9489399
Email: kontakt@guth-hv.de, Web: www.guth-hv.de

AUSTRIA

SWITZERLAND

ITALY

TDK-Lambda Italy
Via dei Lavoratori 128/130
IT 20092 Cinisello Balsamo (MI)
Tel: +39-02-6129-3863, Fax: +39-02-6129-0900
Email: info.italia@it.tdk-lambda.com
Web: www.it.tdk-lambda.com

SCANDINAVIA

BALTICS

Divisoft AB
Rallarvägen 41, SE-184 40 Åkersberga, Sweden
Tel: +46 8 540 248 09, Fax: +46 8 501 096 53
Email: iain@divisoft.se, Web: www.divisoft.se

ISRAEL

RUSSIA

UKRAINE

TDK-Lambda Israel Ltd.
Kibbutz Givat Hashlosa Tel-Aviv 48800
Tel: +972-3-9024-333, Fax: +972-3-9024-777
Email: info@tdk-lambda.co.il, Web: www.tdk-lambda.co.il

BRAZIL

Suplitech
Rua Sena Madureira 455, Belo Hte - 31340-000
Tel: +55-31-3498 1177, Fax: +55-31-3441 0841
Email: vendas@suplitech.com.br, Web: www.suplitech.com.br

MEXICO

AcMax De Mexico
Rosas 139 Col. Bugambillas. Puebla, Pue. C.P. 72580
Tel: +52-800-211-0060, Fax: +52-264-1445
Email: edaena@acmax.mx, Web: www.acmax.mx

JAPAN

KOREA

Electronics Optics Research, Ltd
4-26-19 Koenji-Minami
Suginami-ku, Tokyo 166-0003
Tel: +81-333-145699, Fax: +81-333-142333
Email: imamura@eor.jp, Web: www.eor.jp

CHINA

TDK-Lambda Shanghai Office
2nd Floor of Building No.1, No.15 Guiqing Road,
Shanghai, 200233 P.R. China
Tel: +86-21-64850777, Fax: +86-21-64850666
Email: sales-sh@cn.tdk-lambda.com
Web: www.cn.tdk-lambda.com

MALAYSIA

TDK-Lambda Malaysia
No.7.3, 7th Floor, Jaya Shopping Center,
Jalan Semangat Section 14, 46100
Petaling Jaya Selangor, D.E
Tel: +60-3-7957-8800 Fax: +60-3-7958-2400
Web: www.tdk-lambda.com.my

SINGAPORE

PHILIPPINES

THAILAND

TDK-Lambda Singapore
1008 Toa Payoh North # 06-01/08
Singapore 318996
Tel: +65-6251-7211 Fax: +65-6250-9171
Web: www.se.tdk-lambda.com

INDIA

TDK-Lambda India
#526, Ground Floor, 10th Main, 7th Cross,
Jeevanbhimanagar, Bangalore 560 075, Karnataka, India
Tel : +91-80-43550500, Fax :+91-80-43550501
Email: mathew.philip@in.tdk-lambda.com
Web www.in.tdk-lambda.com

SOUTH AFRICA

PaR Systems (Pty) Ltd.
Pretoria, South Africa
Tel: +27-12-5480370, Fax: +27-12-5480447
Email: ndupreez@par.com
Web: www.sdilasers.com



TDK-Lambda Americas Inc. 405 Essex Road, Neptune, NJ 07753 USA
Tel: +1 732 922 9300 Fax: +1 732 922 1441
www.us.tdk-lambda.com/hp

93 008 009 Rev G

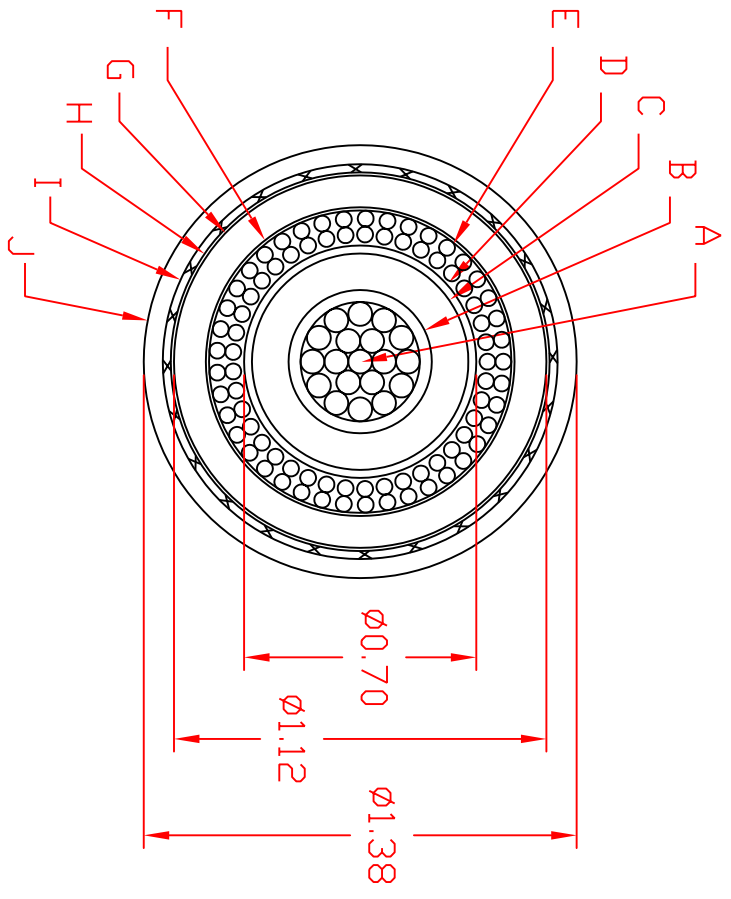

LEGEND

- A. #00 (19 X BARE COPPER COMPACTED), NOMINAL Ø 0.376
- B. SEMICONDUCTING EPR, Ø 0.42
- C. INSULATING EPR - Ø 0.115 WALL TO Ø0.65
- D. SEMICONDUCTING EPR, Ø 0.70
- E. OUTER CONDUCTOR, DOUBLE LAYER, 12 INCH LAY RHL INNER 41 x #18 AWG (19 x 30AWG T.C.) LHL OUTER 41 x #18 AWG (19 x 30AWG T.C.)
- F. SEMICON TAPE, 2" WIDE, 0.005 THK
- G. INSULATING LDHMMW POLYETHYLENE 0.100 WALL.
- H. SEMICON TAPE, 2" WIDE, 0.005 THK
- I. BRAID, #28 AWG T.C., 6 ENDS, 24 CARRIER, 70% COVERAGE.
- J. JACKET, PVC, BLACK, 0.06 WALL.

REVISIONS

REV	ECO NUMBER	APPD	DATE

THIS DOCUMENT AND THE INFORMATION CONTAINED IN IT ARE THE PROPERTY OF DIELECTRIC SCIENCES, INC AND SHALL NOT BE REPRODUCED OR COPIED OR USED AS THE BASIS FOR THE MANUFACTURE OF APPARATUS WITHOUT PERMISSION.

UNLESS OTHERWISE SPECIFIED

DIMENSIONS ARE IN INCHES TOLERANCE ON

DECIMALS .XX ±.01	ANGLES ±
.XXX ±.005	

CONCENTRICITY .005 TIR REMOVE BURRS & SHARP EDGES ALL MACHINE SURFACES 125V



DRAWN	DATE
D. ABDULKY	14 JAN 16
CHECKED	DATE
APPROVED	DATE
MATERIAL	
FINISH	

DIELECTRIC SCIENCES, INC			
CHELMSFORD, MASSACHUSETTS 01824			
HV CABLE			
SIZE	FSCM NO.	DWG NO.	REV
A	50509	SK160114	1
SCALE		SHEET	OF

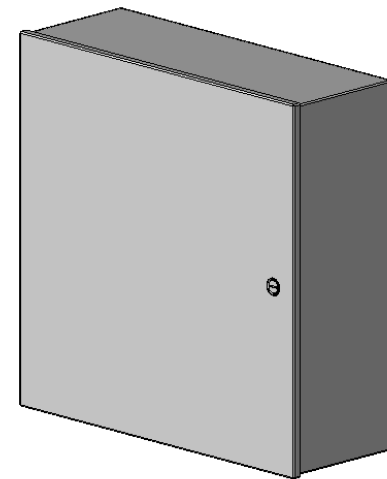
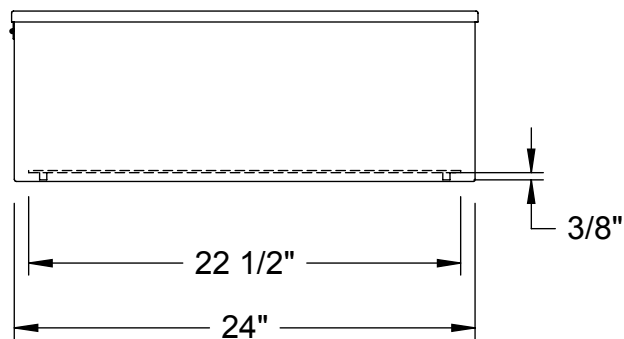
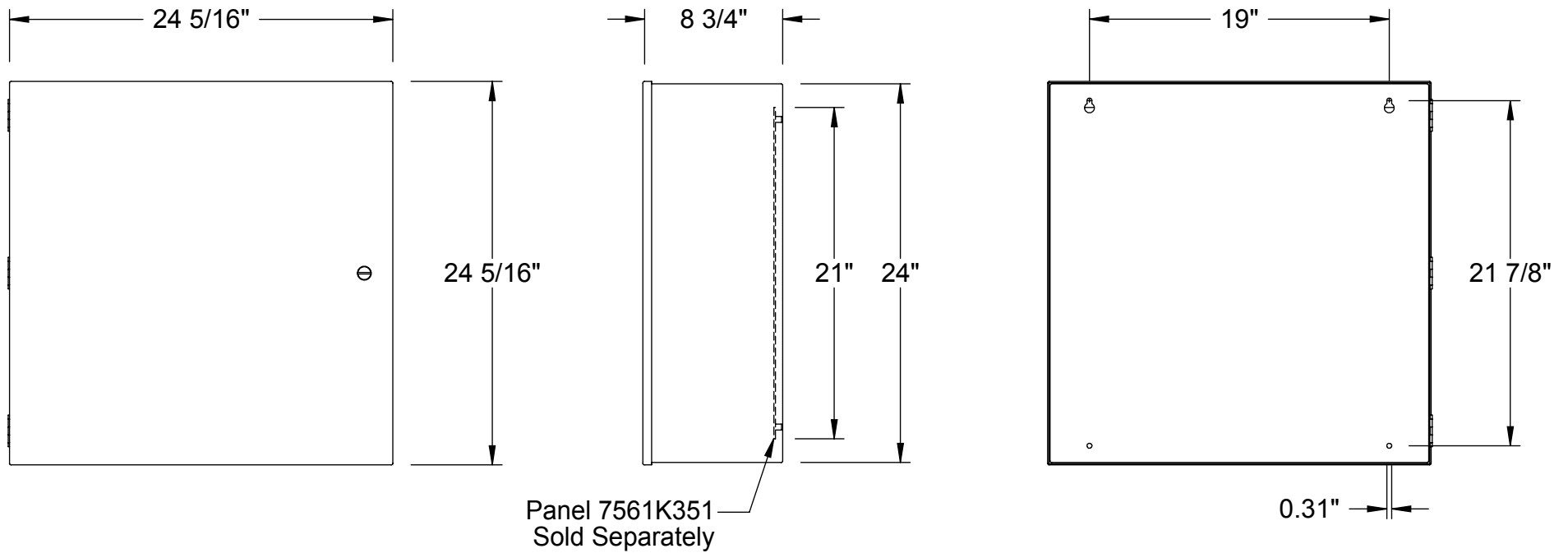

14-ga Steel (0.0747")

Approximate Internal Dimension: Ht. 23", Wd. 23", Dp. 8 1/8"

McMASTER-CARR CAD

PART
NUMBER

7561K64

<http://www.mcmaster.com>
© 2014 McMaster-Carr Supply Company

Indoor Steel
Enclosure

Information in this drawing is provided for reference only.